

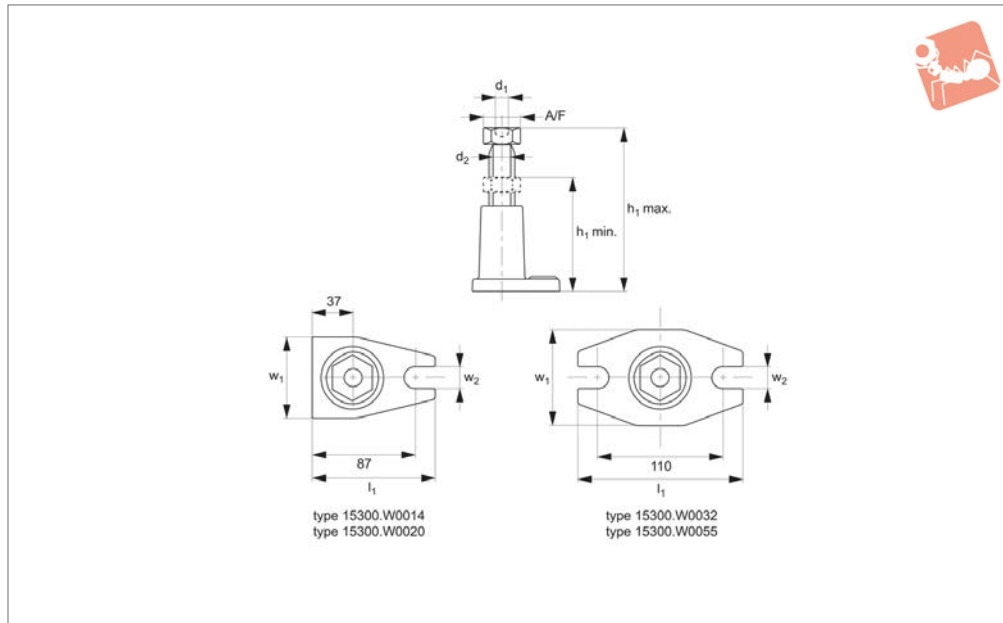

# Atlas Screw Jacks with counter locking nut

## Screw Jacks



# 15300

SCREW JACKS

### Material

Housing: cast iron, enamelled.  
Spindle: carbon steel, trapezoidal thread 30x6.

### Technical Notes

Centering hole  $\varnothing 12\text{mm}$ .

See technical pages for the table of locating pad and support locating element suitability.

### Tips

When using in conjunction with forked clamps, we recommend the use of locating

pads no. 15040 when the slot width of the clamps is  $>26\text{mm}$ .

### Important Notes

**Do not adjust screw jacks under load.**

| Order No.          | $h_1$<br>min. | $h_1$<br>max. | $d_1$ | $d_2$ | $w_1$ | $w_2$ | $l_1$ | A/F | Static load<br>kN<br>max. | Weight<br>g |
|--------------------|---------------|---------------|-------|-------|-------|-------|-------|-----|---------------------------|-------------|
| <b>15300.W0014</b> | 100           | 140           | 12    | 30x6  | 75    | 18    | 110   | 46  | 60                        | 1800        |
| <b>15300.W0020</b> | 140           | 200           | 12    | 30x6  | 75    | 18    | 110   | 46  | 60                        | 2200        |
| <b>15300.W0032</b> | 200           | 320           | 12    | 30x6  | 90    | 22    | 160   | 46  | 40                        | 3800        |
| <b>15300.W0055</b> | 320           | 550           | 12    | 30x6  | 90    | 22    | 160   | 46  | 25                        | 4900        |

