

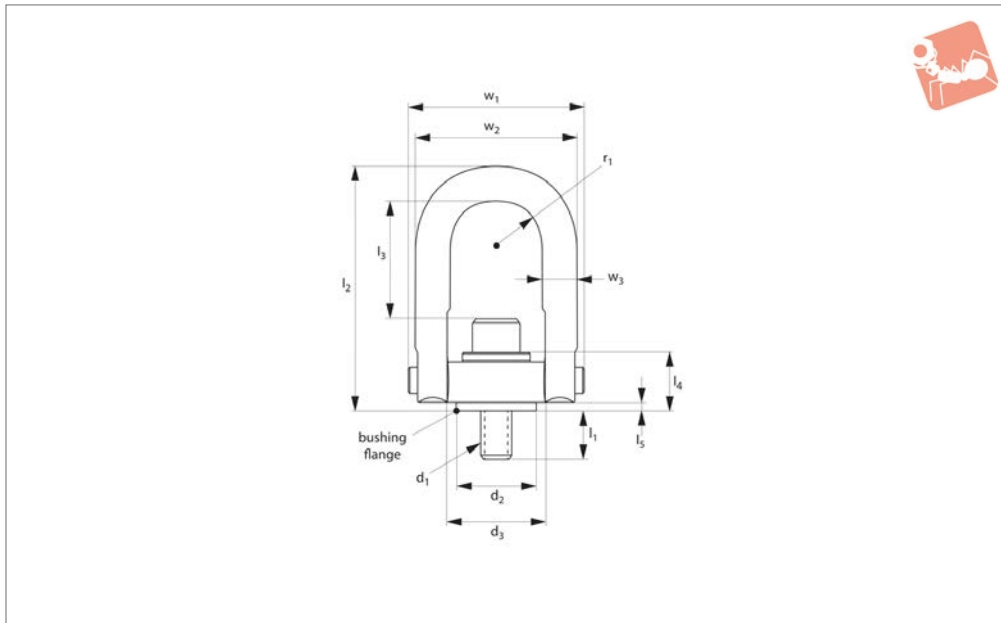

Lifting Points - Double Swivel - Male standard bar - metric - coarse

Lifting Points & Shackles



63521

LIFTING POINTS & SHACKLES

Material

Forged alloy steel (4140), min. tensile strength 180,000psi. Black oxide coated.

ments of ASME -B30.26 and MIL-STD 209. Magnetic particle inspected per ASTM 1444.

and 180° pivot underload. Each part individually serial numbered.

tl = recommended torque load (Nm).

Technical Notes

Meets manufacturing and design require-

Tips

Min. design safety factor 5:1. 360° swivel

Important Notes

Always follow safety instructions.

Order No.	Rated load tonnes (t)	d ₁	d ₂	d ₃	l ₁	l ₂	l ₃	l ₄	Weight kg
63521.W0081	0.40	M 8x1,25	19.10	25.40	17	67.80	32.10	18.0	0.14
63521.W0101	0.45	M10x1,50	19.10	25.40	17	67.80	30.20	18.0	0.14
63521.W0121	1.05	M12x1,75	38.00	50.50	19	121.40	59.40	31.0	1.05
63521.W0161	1.90	M16x2,00	38.00	50.50	24	121.40	55.40	31.0	1.11
63521.W0201	2.20	M20x2,50	38.00	50.50	30	121.40	51.40	31.0	1.16
63521.W0202	3.00	M20x2,50	58.70	76.20	29	165.80	77.00	43.4	3.06
63521.W0241	4.20	M24x3,00	58.70	76.20	34	165.80	73.00	43.4	3.18
63521.W0301	4.50	M30x3,50	58.70	76.20	54	165.80	67.00	43.4	3.30
63521.W0302	7.00	M30x3,50	81.30	95.50	46	221.70	106.30	53.6	6.36
63521.W0303	7.00	M30x3,50	81.30	95.50	66	221.70	106.30	53.6	6.70
63521.W0361	11.00	M36x4,00	106.70	123.70	69	316.70	164.80	71.4	15.34
63521.W0421	12.50	M42x4,50	106.70	123.70	79	316.70	158.80	71.4	15.91
63521.W0481	13.50	M48x5,00	106.70	123.70	79	316.70	152.80	71.4	16.36
63521.W0641	22.00	M64x6,00	146.10	165.60	102	428.50	230.30	104.0	39.77
63521.W0721	31.50	M72x6,00	184.15	205.74	132	495.30	215.39	133.9	75.45
63521.W0901	51.00	M90x6,00	196.85	218.44	178	561.09	235.71	153.9	109.09

Order No.	l ₅	r ₁	w ₁	w ₂	w ₃	tl Nm
63521.W0081	4.30	10.90	46.70	40.9	9.50	9.5
63521.W0101	4.30	10.90	46.70	40.9	9.50	16.0
63521.W0121	4.10	22.40	89.40	82.5	19.00	37.0
63521.W0161	4.10	22.40	89.40	82.5	19.00	80.0
63521.W0201	4.10	22.40	89.40	82.5	19.00	135.0
63521.W0202	6.10	35.60	130.50	121.2	25.40	135.0
63521.W0241	6.10	35.60	130.50	121.2	25.40	311.0
63521.W0301	6.10	35.60	130.50	121.2	25.40	311.0
63521.W0302	8.90	44.50	165.10	152.4	31.80	637.2
63521.W0303	8.90	44.50	165.10	152.4	31.80	637.2
63521.W0361	11.90	57.20	217.20	203.2	44.50	1085.5
63521.W0421	11.90	57.20	217.20	203.2	44.50	1085.5
63521.W0481	11.90	57.20	217.20	203.2	44.50	1085.5



Order No.	l_5	r_1	w_1	w_2	w_3	tl Nm
63521.W0641	28.40	76.20	296.40	266.7	57.20	2847.5
63521.W0721	25.40	95.25	368.30	330.2	69.85	5670.0
63521.W0901	27.69	101.60	403.86	368.3	82.55	9560.0



Heavy duty safety hoist rings are stronger than competitive lifting devices, providing better value while delivering the quality and safety only the best design and manufacture can achieve.

- Manufactured from high strength alloy steel.
- One piece body and shouldered d-ring element.
- Just 6 component parts for increased safety.

The patented shoulder pin used in our heavy duty safety hoist rings allows for rotation of the pin, without shearing of any retaining dowel pin which is so often used in the construction of other competitive hoist rings. This unique design element enables disassembly of our hoist rings for inspection, compliance testing and reassembly.

General maintenance and care

Improper maintenance and inspection of your hoist ring could result in damaged equipment, personal injury or even death. In order to ensure maximum safety please read, understand and follow these maintenance and inspection guidelines prior to using any lifting hoist ring.

- When not in use, store hoist rings carefully to prevent corrosion or accidental damage.
- Do not remove the installation and safety tag from the lifting device. Ensure the identification tag remains legible during the life to the lifting device.

Maintenance

Visually inspect the lifting device prior to any use. Frequency of inspection should increase with the frequency of use, severity of service conditions and the more safety critical the use of the device. Discontinue use of any lifting device if inspection identifies any of the following:

- Missing identification tags.
- Indications of heat damage.
- Excessive corrosion or pitting.
- Damaged or missing load bearing components.
- Excessive nicks or gouges.
- Excessive thread damage.
- Evidence of unauthorised welding or modification.
- Lack of ability to swivel 360° or pivot 180°.

Inspection

Important installation and operation instructions

Installation

- Ensure thread has been tapped perpendicular to the mounting surface. Mounting surface should be flat to provide full 360° flush seating for the hoist ring.
- For installation in ferrous metal ensure bolt is tightened to the full torque load +0-20% (as specified on the product data sheet).
- To ensure the 5:1 design safety factor we recommend the ultimate tensile strength of the mating material to be min. 80,000 psi.
- For weaker mating material consider using longer bolts or through hole mounting with a nut and washer on the back side. To prevent stripping the mating thread, lower torque values (down to half the stated value) may be considered in temporary installations.
- On completion of installation check the lifting ring can swivel and pivot freely in all directions.
- Use at temperatures between -30°C and +200°C

Safety notes

- Never exceed the working load limit.
- Visually inspect the hoist ring for damage before each use.
- Loosening of the a bolt may develop after prolonged service, it is advisable to periodically retighten to the specified torque value.
- Apply lifting loads gradually to avoid shock loads.
- Use of free fit spacers between the lifting ring bush flange and the mounting surface is not recommended.
- Do not over size hooks nor use attachment methods which spread the ring.
- It is important to align the lifting ring with ~the direction of the load.
- Do not attach guidelines to hoist rings.
- Do not leave a gap between lifting ring bushing and mounting surface.
- Never allow personnel to walk underneath a suspended load.

It is very important for you to read and comply with these installation and safety notes prior to use or any lifting device.



Formula to calculate the load per lifting ring

$$F = \frac{W}{N \sin A}$$

F = force on each hoist ring
 N = number of hoist rings
 A = lifting angle
 W = total weight

For example:

If A = 65° $F = \frac{4000}{4 \sin 65^\circ} = 1103 \text{ lbs.}$

If A = 14° $F = \frac{4000}{4 \sin 14^\circ} = 4134 \text{ lbs.}$

Important note: The force exerted on each hoist ring is not simply a function of the total weight divided by the number of hoist rings, but is critically reliant upon the lifting angle, greater forces are present the lower the lifting angle. See example below.

Angular lifting

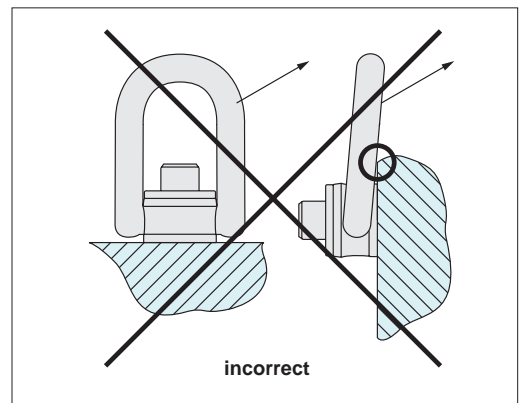
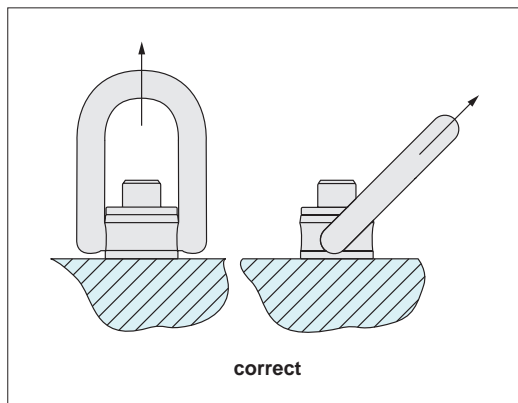
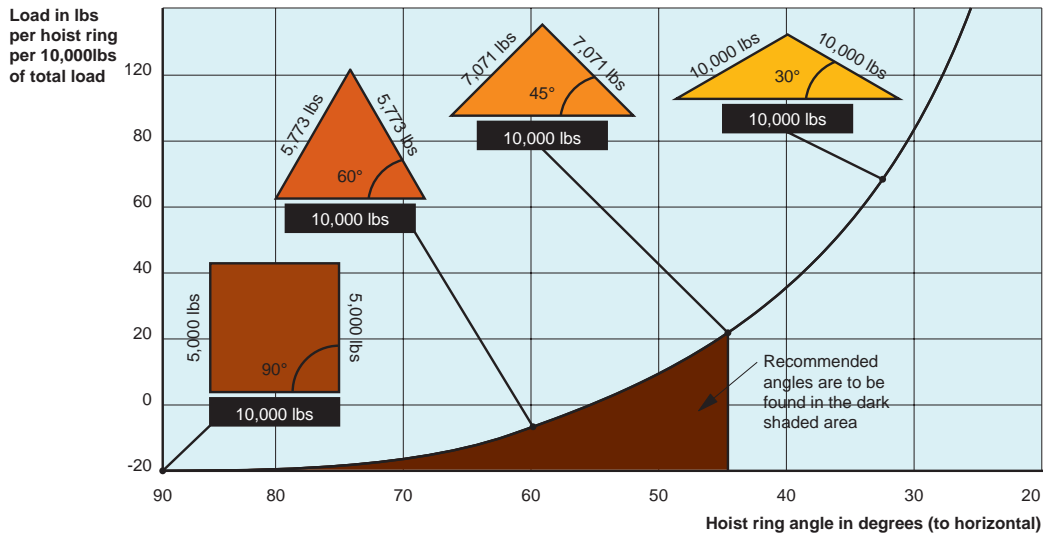

Do not allow the lifting ring to bind/stick and hence apply side loads to the bail. Ensure loads applied are in the same direction of the bail. If necessary use a spreader bar to avoid binding.

