

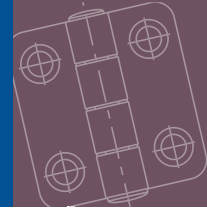

# Concealed Pivot Hinges - Lift Off

21mm door return - weld and oval head screw - steel



Hinges

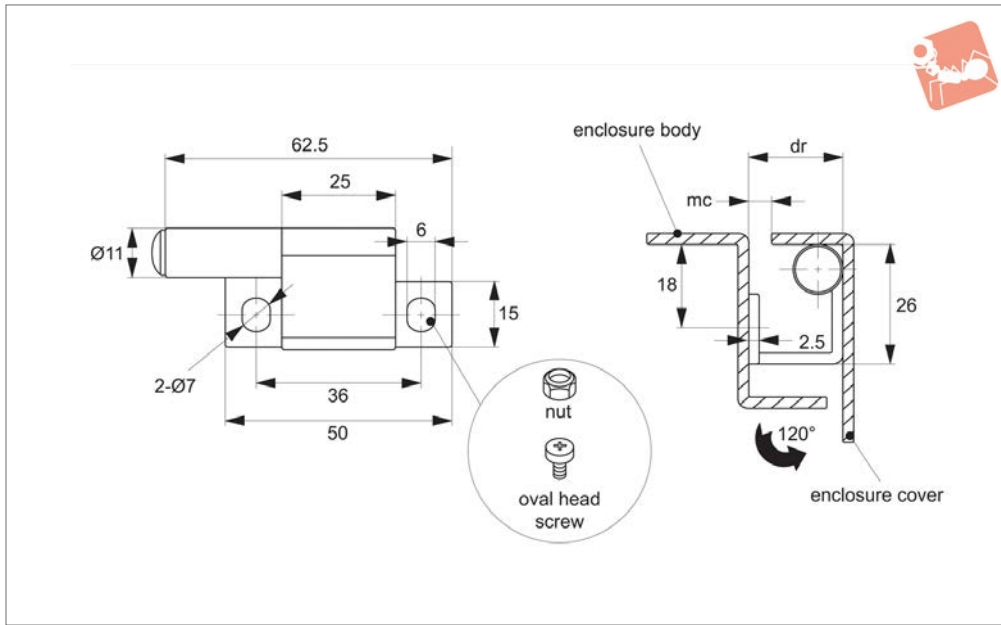

**S2170**

HINGES

**Material**

Hinge: steel, white zinc plated.

**Technical Notes**

Suited to sheet metal and machine enclosures with a 21mm door return. Main body

mounted via two M7 screws, hinge plate welded to frame.

Opening angle: 120°.

**Important Notes**

dr= Maximum door return suitable for use

with hinge.

mc= Minimum clearance advised between enclosure cover and body to ensure smooth, full opening of enclosure cover.

Order No.	Door return	Size	F <sub>x</sub> N	F <sub>y</sub> N	mc min.	ts panel thickness
S2170.AW0021	21	50 x 26 x 21	200	160	4	2.5

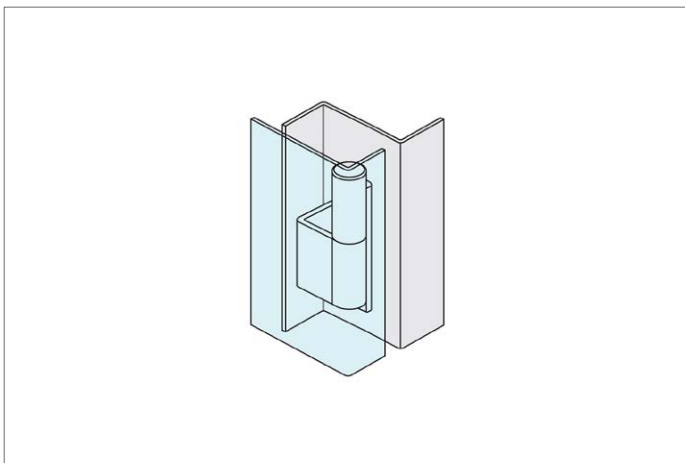

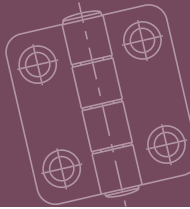

### A variety of mounting methods are available!

#### Mounting combinations

Wixroyd concealed hinges can be mounted in a variety of ways using additional nuts and bolts.

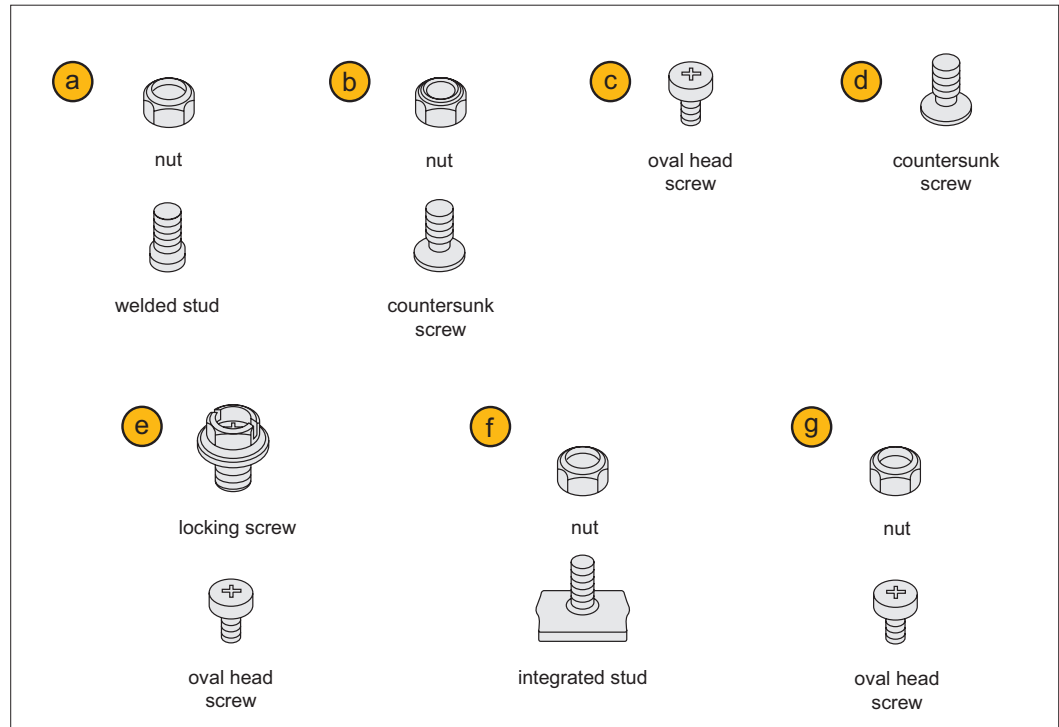

**Important Note:** Refer to individual product pages for suitable mounting options. If you have any problems please contact our Technical Sales Team.

#### Mounting example

In the example, mounting option ②, a nut with a countersunk screw, is used to mount the hinge onto the enclosure body.

