

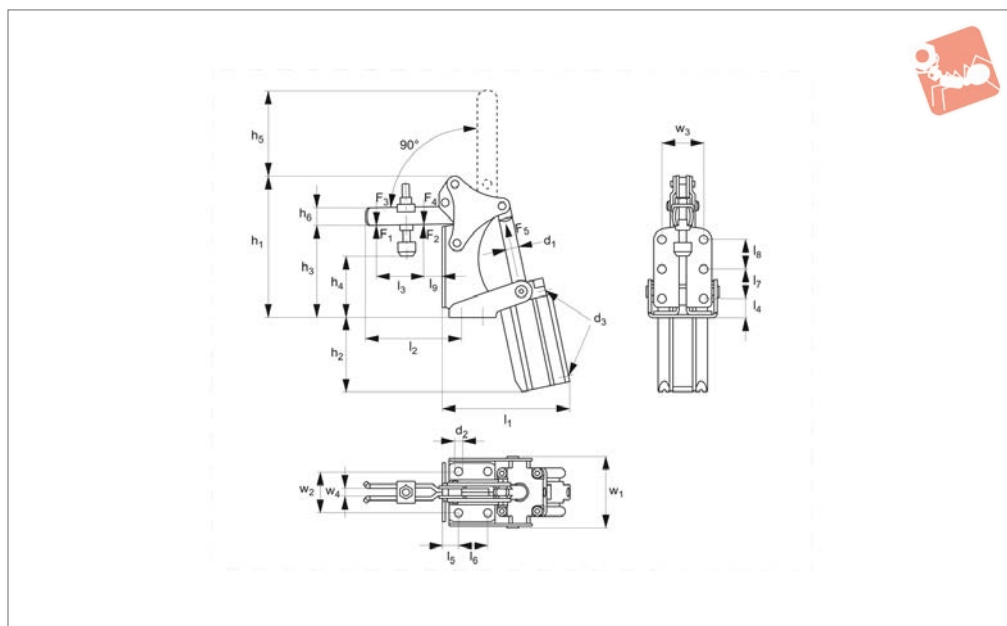

# Pneumatic Toggle Clamp with vertical cylinder

## Pneumatic Toggle Clamps



### 47060

PNEUMATIC TOGGLE CLAMPS

#### Material

Body: steel, zinc plated.  
Bushes: case hardened and greased.  
Rivets: stainless steel.  
Complete with tempered, white zinc plated clamping screw.

#### Technical Notes

Bearings are pre-lubricated.  
Clamp ready for installation and consists

of:  
- vertical toggle clamp no. 40000 (without handle)  
Pneumatic cylinder, double acting.  
 $F_3$  and  $F_4$  = max. clamping force at 6 bar.  
 $V_n$  = air consumption per double stroke in  $dm^3$  at 6 bar.  
Suitable proximity switches for end-position monitoring are available using

order 45001. 0.3m PUR cable with M8 connector and rotatable knurled nuts.  
Switching function: NOC.  
Output: PNP.

#### Tips

The console is self-supporting and must be clear of other surfaces. There is a valve for controlling the speed of operation.

Order No.	Size	$F_1$ kN	$F_2$ kN	$F_3$ kN	$F_4$ kN	$F_5$ kN	Clamping screw	Piston dia.	$h_1$	$h_2$	$h_3$	$h_4$ min.	$h_4$ max.	$h_5$	$h_6$	Weight g
47060.W0002	2	1.0	1.2	0.70	1.0	0.30	M 6x35	25	100.5	67.5	65.0	38.4	45.0	43	12	625
47060.W0003	3	1.0	2.5	0.65	1.1	0.50	M 8x45	32	114.5	78.0	68.7	38.0	46.5	69	18	1025
47060.W0004	4	2.0	3.0	1.50	2.2	0.75	M 8x65	40	153.0	80.0	100.0	51.0	80.0	92	20	1700

Order No.	$l_1$	$l_2$	$l_3$	$l_4$	$l_5$	$l_6$	$l_7$	$l_8$	$l_9$	$w_1$	$w_2$	$w_3$	$w_4$	$d_1$	$d_2$	$d_3$	$V_n$ $dm^3$
47060.W0002	83.0	56.5	25	15.9	15.3	13	13	12.5	6.5	27	6	54.5	26.6	12	5.6	M 5	0.3
47060.W0003	96.0	80.5	36	17.5	16.5	16	16	-	12.5	25	8	62.5	25.0	16	6.5	G1/8	0.4
47060.W0004	123.5	102.0	49	20.5	17.5	32	32	32.0	19.0	45	10	77.5	45.0	16	8.5	G1/4	0.8