

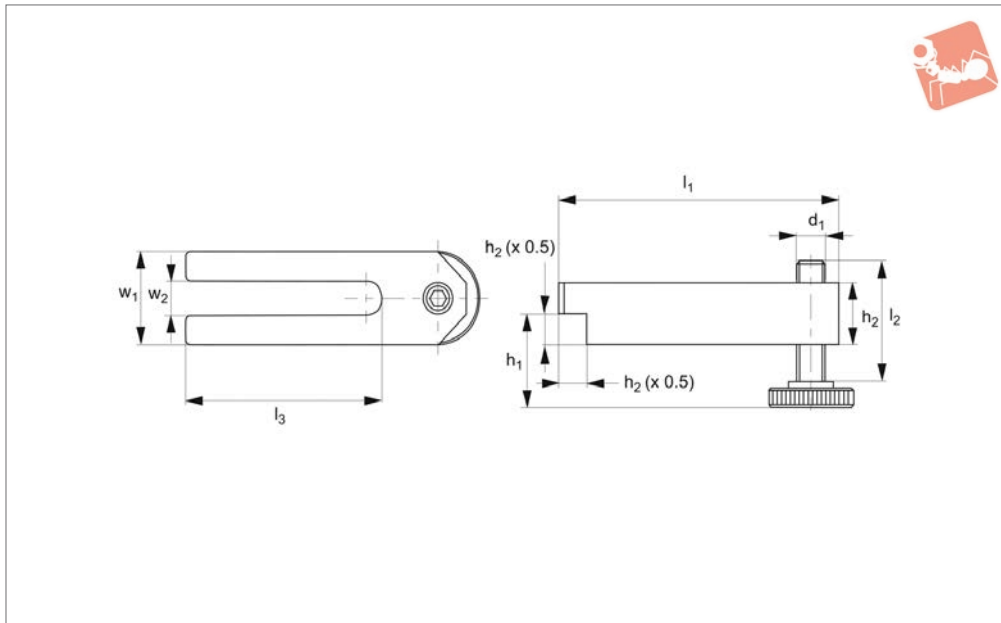

Slotted Stepped Clamp with adjusting support screw

Standard
Manual Clam-



10240

STANDARD MANUAL CLAMPING

Material

Steel, heat-treated and enamelled.

Technical Notes

To clamp thin parts, turn the clamp over.

Order No.	For clamping screw	$d_1 \times l_2$	l_3	w_1	$w_2 \times l_1$	h_1	h_2	Weight g
10240.W0010	M10	M10x39	70	30	11x100	8-47	20	330
10240.W0014	M12, M14	M12x49	90	40	14x125	10-59	25	700
10240.W0018	M16, M18	M16x55	110	50	18x160	13-67	30	1300
10240.W0022	M20, M22	M20x69	135	60	22x200	16-85	40	2600