

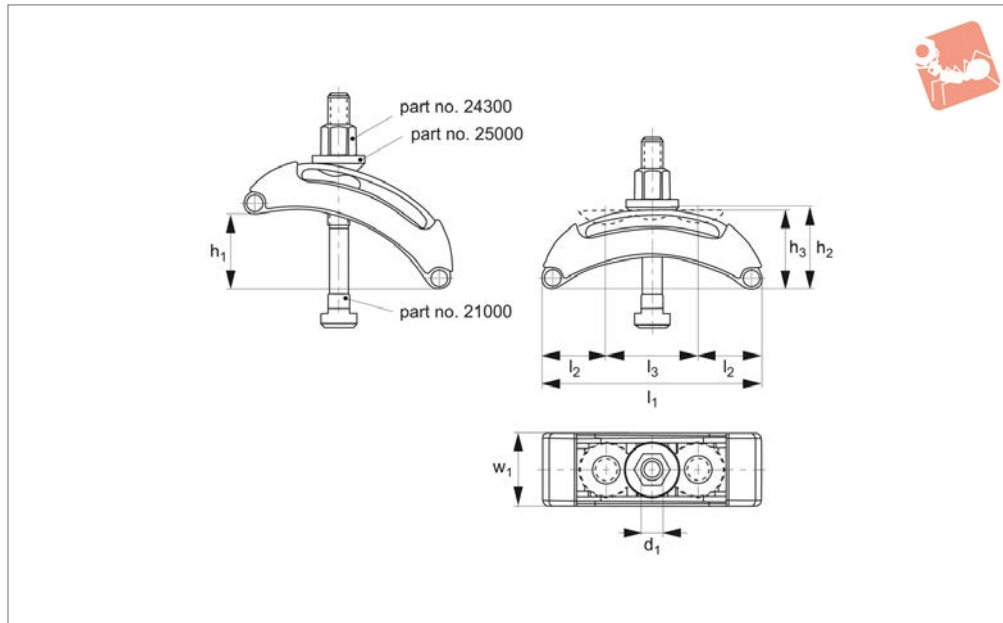

Clamp - Plastic Cover

complete with T-bolt set

Adjustable Vertical Clamps



10630.2

ADJUSTABLE VERTICAL CLAMPS

Material

Steel, tempered and burnished.

Technical Notes

Complete with T-bolt set. Weight-saving thanks to its lightweight design. Variable

and fast adjustment at a distance from the workpiece. No additional clamping supports are needed to reach the required clamping height. The U-piece is undetachable from the clamp.

Tips

A washer (DIN 6340) must always be used between the hexagonal nut and U-piece. h_1 is dependent on depth of slot to DIN 650 and position of fixture nut.

Order No.	Size	With clamping bolt	h_1 min. max.	h_2	h_3	l_1	l_2	l_3	w_1	d_1	Weight g
10630.W0110	10	M10x10x80	0-15	32.0	30.5	80	30	19	44	11	349
10630.W0112	12	M12x12x100	0-33	49.5	47.0	125	37	51	57	14	886
10630.W0114	14	M12x14x125	0-33	49.5	47.0	125	37	51	57	14	905
10630.W0116	16	M16x16x160	0-45	62.0	58.5	160	49	63	67	18	1648
10630.W0118	18	M16x18x160	0-45	62.0	58.5	160	49	63	67	18	1668

