



Tapered Locating Bushes

for single clamping module - flanged 12043



Bore Clamping

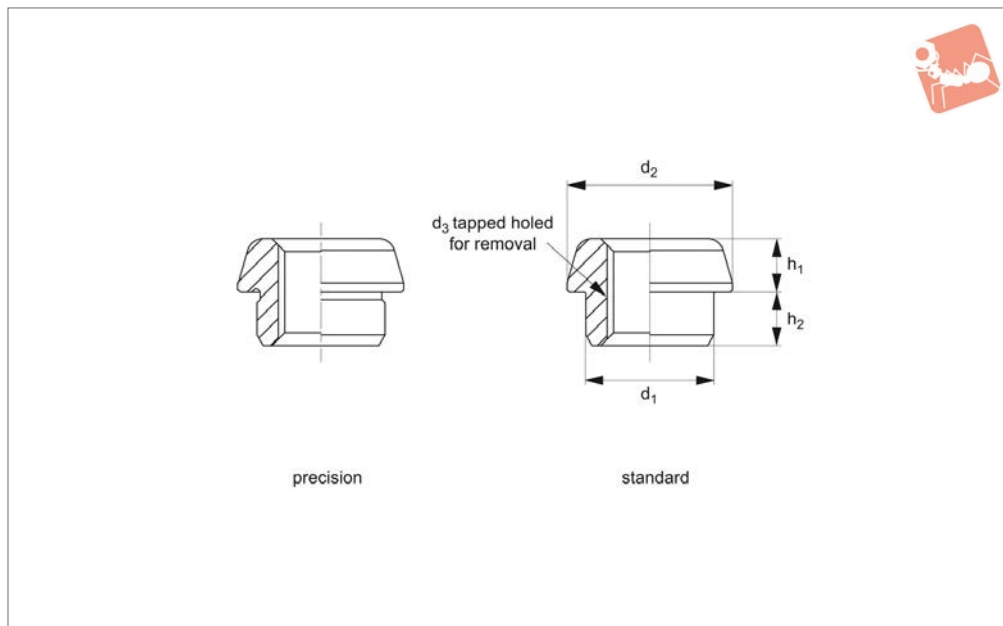

12048.2

BORE CLAMPING

Material

Steel (C45E), tempered, black oxide finish, precision ground (precision type only)

Technical Notes

Can be used to increase the accuracy of

flanged single clamping module (see part no. 12043) location on the fixture plate. Can achieve clamping module locating repeatability of up to 5 microns (precision type), or 0,1mm (standard type).

Only the precision type is precision ground for increased locating accuracy.

Order No.	h_1	h_2	Suitable clamping module 12043	Type	Size	d_2	d_3	Precision d_1 tol. g6	Standard d_1 -0.02 -0.05	Weight g
12048.W0108	4	5.0	8	Standard	8	11.5	M 6x1,00	-	8	4
12048.W0111	5	5.0	11	Standard	11	15.5	M 8x1,25	-	12	8
12048.W0116	8	6.0	16	Standard	16	24.5	M12x1,75	-	18	27
12048.W0121	10	7.5	21	Standard	21	31.5	M16x2,00	-	22	51
12048.W0208	4	5.0	8	Precision	8	11.5	M 6x1,00	8	-	4
12048.W0211	5	5.0	11	Precision	11	15.5	M 8x1,25	12	-	8
12048.W0216	8	6.0	16	Precision	16	24.5	M12x1,75	18	-	27
12048.W0221	10	7.5	21	Precision	21	31.5	M16x2,00	22	-	51