

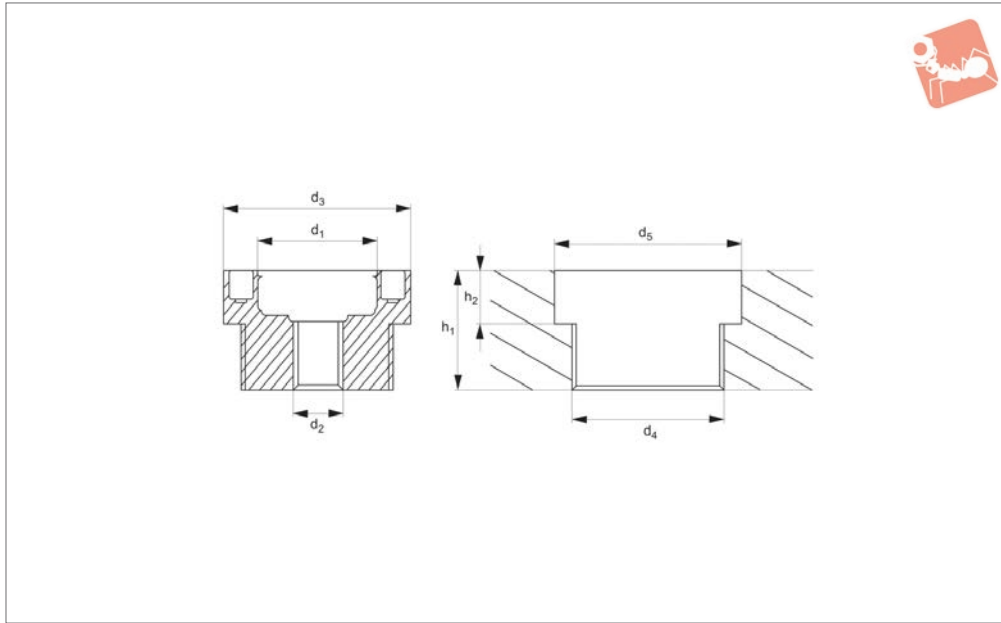

Face Mount Receivers - Compact



Pull Back Inserts



12097.2

PULL BACK INSERTS

Material

Heat-treated steel alloy with black oxide finish. High tensile strength (180 000 PSI or 1241 MPa) and hardness (50-52 HRC).

Technical Notes

Precision machined to ± 0.0002 " tol. Repeatability of $.0004$ " or better. Compact face mount design optimises

subplate space, is easier to install, stronger and less expensive than standard face mount receivers.

Order No.	d ₁ mm +0.010 -0.000	d ₂ inch	d ₃ inch	d ₄ UNF-2B	d ₅ inch +0.0004 -0.0000	h ₁ inch min.	h ₂ inch +0.010 -0.005
12097.W2131	13	1/4-20	0.9500	3/4-16	0.9504	3/4	,300
12097.W2161	16	5/16-18	1.0625	7/8-14	1.0629	3/4	,300
12097.W2201	20	3/8-16	1.2750	1-12	1.2754	1	,390
12097.W2251	25	1/2-13	1.5000	1-1/4-12	1.5004	1	,390
12097.W2301	30	5/8-11	1.8125	1-1/2-12	1.8129	1-1/4	,505
12097.W2351	35	3/4-10	2.1250	1-1/2-12	2.1254	1-5/16	,630
12097.W2501	50	1-8	2.7500	2-12	2.7504	1-3/4	,765



Quick and Easy to Use with Every Load

System Overview

The Wixroyd Precision Locating & Mounting System consists of locators, receivers and bushings for a wide range of tooling, fixturing, workholding, production, welding and assembly applications. They offer the ability to make fast, accurate set-up changes which enables significant improvements in machining productivity, throughput rates, quality and reduced operating costs.

Wixroyd has solved the typical problems associated with precision attachment and removal of fixture plates, tooling and accessories. The Wixroyd system eliminates the need to pry, pound and use jack screws to separate the fixture plate from the sub-plate or machine table. The Wixroyd system uses a threaded fastening device to mechanically extract the precision locator from its receiver, allowing easy separation of fixture plates, tooling and accessories. Unlike competitive ball locking products, the Wixroyd system does not require expensive "repair kits" since there are no rubber o-rings to break nor ball bearings to fall out or fracture.

Usage

- Place fixture plate over sub-plate or machine table containing the Wixroyd receivers.
- Insert two Wixroyd precision locators through holes lined with hardened bushings and into the receivers.
- Insert two remaining locators into unlined holes and tighten to draw each locator to the desired torque.
- Total time require to unload existing fixture plates and load a new fixture plate is typically under 2 minutes.

System Features

- Self- extracting – unique design enables easy and quick "self-extract" from tooling, fixturing etc. There is no binding or other issues to delay removal time or compromise accuracy of the locking system.
- Precise locating – repeatability of +/- 0.0004"
- High clamping strength – over 45,000 lbs
- Easy Installation – easily installed in a wide range of applications using standard tooling and machining practices.
- Compact – requires minimal space in tooling and fixture applications. Both standard and compact/flush mounting options.
- Can be retro-fitted with existing competitive ball lock type systems.

Product Range



12095.W0131 to .W0504 -
Locator unit - standard



12095.W2131 to .W2504 -
Locator unit - compact



12097.W0131 to .W0501 -
Face mount receivers
- standard



12097.W2131 to .W2501
- Face mount compact
receivers - compact



Precision Locating and Mounting System

FAQs

- Q. What is the Wixroyd Precision Locating & Mounting System?**
 A. It is a means of locating and locking two flat surfaces together. These surfaces are most commonly a fixture plate and sub-plates, however, they are also used in many other applications because of their holding strength and accuracy.
- Q. How does it locate the fixture plate?**
 A. The Wixroyd system locates with receivers in the base plate, liner bushings in the sub-plate and locator/fasteners locking the two surfaces together.
- Q. How many locators are needed to locate and fasten the fixture plate?**
 A. Two locators with liner bushings are required to accurately position and two locators without liner bushings to fasten only.
- Q. How does it fasten?**
 A. Locators use standard threads to hold the two surfaces together. By tightening the locators into the receivers very high holding forces can be achieved.
- Q. Can the Wixroyd system be mounted so the work pieces mounting surface is free from any interference?**
 A. Yes, our compact of flush locators allow the head to lie flush with the fixture plate surface.
- Q. Can the system be used in high temperature applications?**
 A. Yes, because all parts are made from heat treated alloy steel, temperatures up to +500F are not a problem. The user should account for thermal expansion of the fixture plates and bases that could affect tolerances.
- Q. Can Fixture plates be mounted in both the horizontal and vertical positions with the Wixroyd system?**
 A. Yes, in vertical mounting applications Wixroyd offer optional docking hardware to “hang” the fixture plate from the tooling column before fastening the surfaces together.
- Q. Can a current ball locking type system be retrofit to work with the Wixroyd system?**
 A. Yes, the universal bolt-in receiver will fit directly into the pocket that holds ball locking type receivers. Also, the Wixroyd system locators will fit the existing holes and liners of a fixture plate set up for ball locking systems.

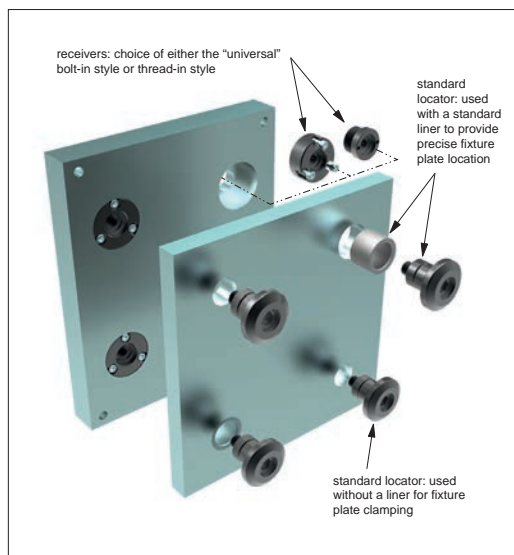

Standard locators

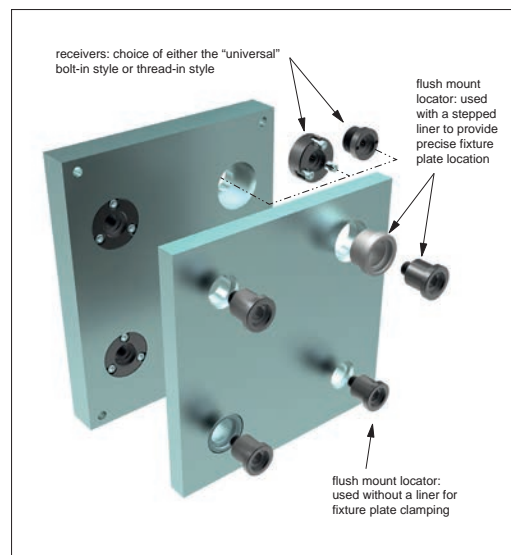

Flush mount locators

Applications