

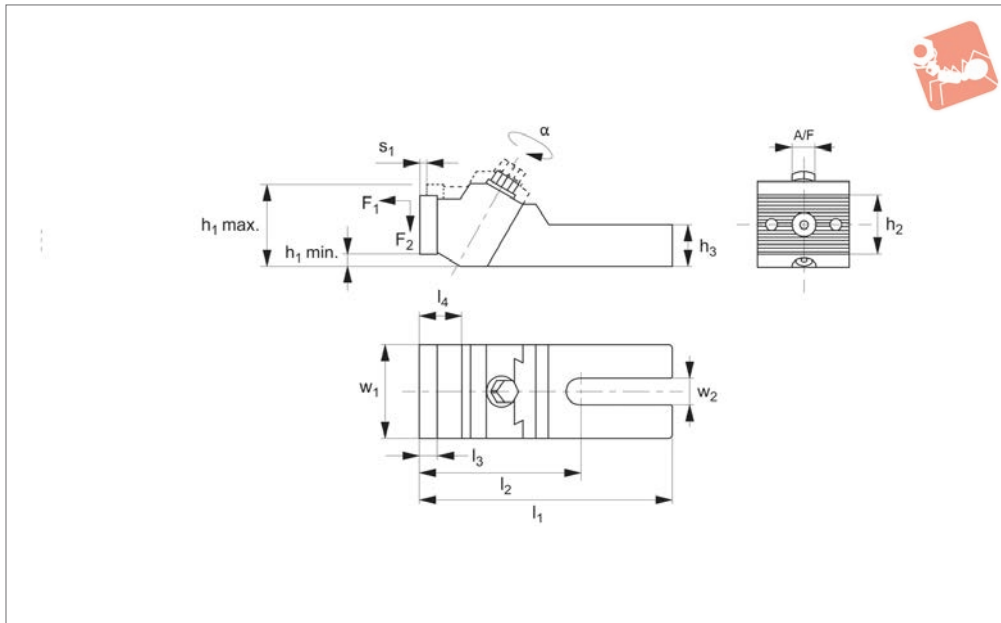

Pull-Down Clamps

solid clamping jaws

Heavy-Duty Side Clamping



12318

HEAVY-DUTY SIDE CLAMPING

Material

Body: steel, tempered.
Clamping jaws: steel, case hardened.

Technical Notes

Reversible clamping jaws with smooth side for machined workpieces and serrated side for rough clamping surfaces.

Tips

The large clamping surface makes these solid clamping jaws suitable for laterally clamping workpieces. We recommend using two clamping studs for fastening the solid clamping jaw on the machine table. Screws for T-slots No. 21000 - two screws per

clamping jaw - should be ordered separately as a fastening bolt depending on the width of the machine T-slot.

Important Notes

*Clamping forces F_1 and F_2 depend on the T-slot size.

Order No.	For T-slot	w_1	w_2	h_1 min.	h_1 max.	h_2	h_3	l_1 max.	l_2	l_3	l_4	Stroke s_1	A/F	Weight g
12318.W0012	12-14	40	13	3	33.5	25.4	20	128	82	8	19	3.0	13	840
12318.W0014	12-18	65	19	20	60.0	40	30	177	113	12	29	6.0	16	3020
12318.W0024	20-30	75	26	33	73.0	40	36	224	135	12	29	7.5	18	4880
12318.W0036	32-42	90	38	51	91.5	40	46	256	152	12	34	10.0	21	7715