

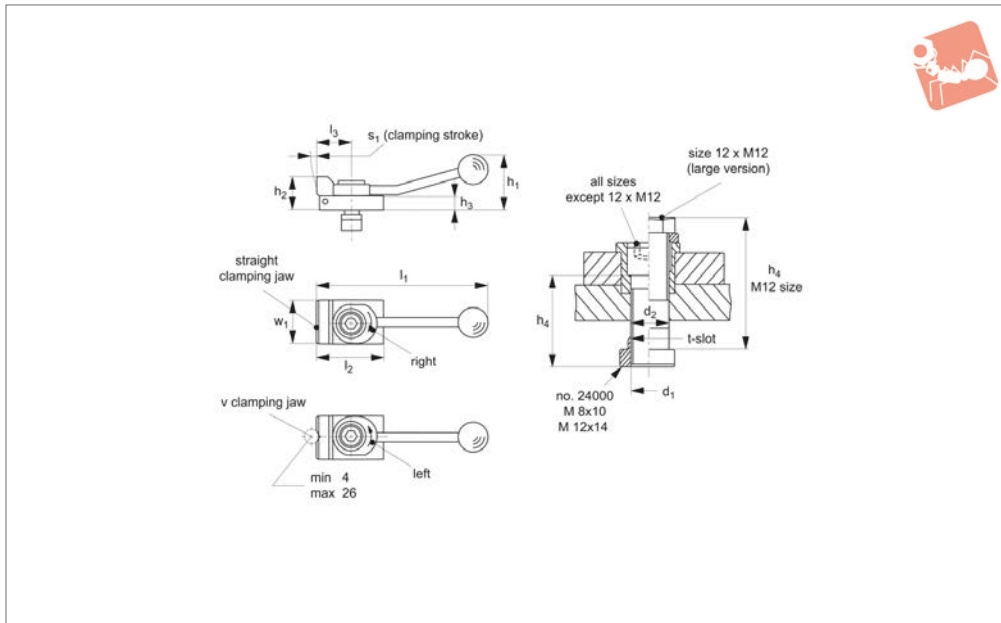

Downhold Clamps with cranked clamping lever

Low Profile Side Clamping



12400

LOW PROFILE SIDE CLAMPING

Material

Steel, case-hardened, blackened.

Technical Notes

For quick clamping from the side. The clamps give forwards and downwards clamping forces.

Tips

Can bridge T-slots when used with holding plate no. 12410. The clamps low profile enables full-face machining. Often used in conjunction with cylindrical stops and bedding supports.

Supplied with standard T-nut. Clamps can be used in other T-slot sizes by selecting T-nuts no. 24000 as required, e.g. M 8x12, M 8x14, M12x16, M12x18.

Order No.	For T-slot	Type	h_1	h_2	h_3	h_4	l_1	l_2	l_3	d_1	d_2	Stroke s_1	w_1	Clamping force horizontal kN max.	Weight g
12400.W0101	10	Straight Jaw, Clamps Right	20	30	8	40	132	50	32	M 8	8,4	3	32	3,5	262
12400.W0321	12	Straight Jaw, Clamps Right	38	60	16	62	190	72	40	M12	12,5	4	48	7,0	870
12400.W0341	14	Straight Jaw, Clamps Right	38	40	16	62	190	72	40	M12	12,5	4	48	7,0	845
12400.W0105	10	Straight Jaw, Clamps Left	20	30	8	40	132	50	32	M 8	8,4	3	32	3,5	262
12400.W0325	12	Straight Jaw, Clamps Left	38	60	16	62	190	72	40	M12	12,5	4	48	7,0	868
12400.W0345	14	Straight Jaw, Clamps Left	38	40	16	62	190	72	40	M12	12,5	4	48	7,0	847
12400.W0102	10	V-Jaw, Clamps Right	20	30	8	40	132	50	32	M 8	8,4	3	32	3,5	263
12400.W0322	12	V-Jaw, Clamps Right	38	60	16	62	190	72	40	M12	12,5	4	48	7,0	893
12400.W0342	14	V-Jaw, Clamps Right	38	40	16	62	190	72	40	M12	12,5	4	48	7,0	838
12400.W0106	10	V-Jaw, Clamps Left	20	30	8	40	132	50	32	M 8	8,4	3	32	3,5	264
12400.W0326	12	V-Jaw, Clamps Left	38	60	16	62	190	72	40	M12	12,5	4	48	7,0	900
12400.W0346	14	V-Jaw, Clamps Left	38	40	16	62	190	72	40	M12	12,5	4	48	7,0	841

Low Profile Side Clamping



Downhold Clamps with cranked clamping lever



LOW PROFILE SIDE CLAMPING

