

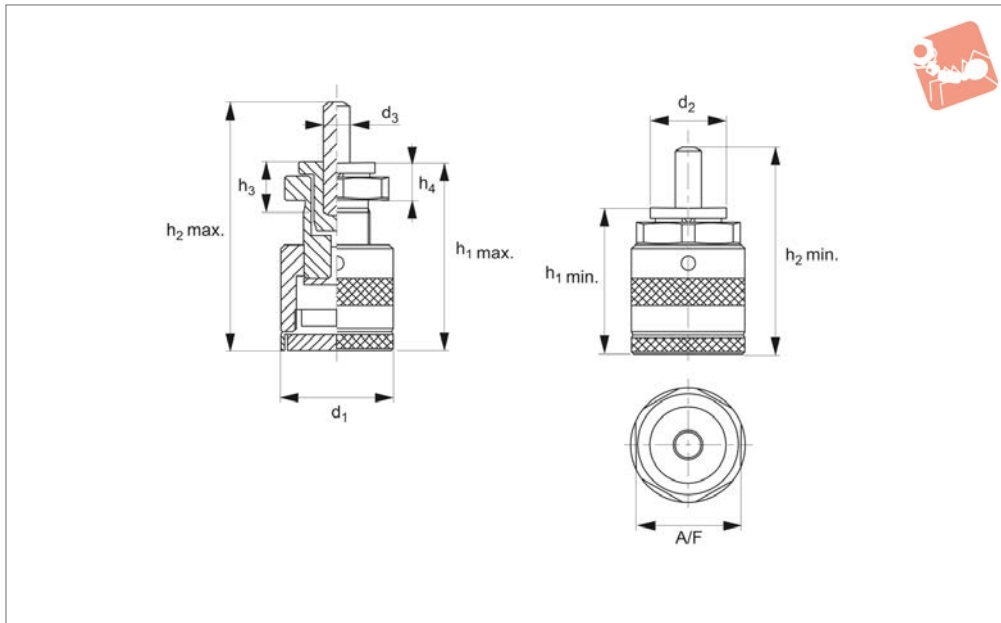

# Height Setting Screw Jacks

magnetic base and locating pins

## Screw Jacks



**15220**

SCREW JACKS

### Material

Body: steel, tempered.

Base: magnetic.

Spindle: M30x1,5 fine thread with end stop.

### Technical Notes

With 2 locating pins ( $\varnothing 12 \times 50$  and  $\varnothing 12 \times 80$ ).

Centering hole  $\varnothing 12 \text{mm}$ . The M30x1.5 fine thread makes precise adjustment possible whilst also preventing the workpiece from turning.

See technical pages for the table of locating pad and support locating element compatibility.

### Tips

A bearing insert prevents the workpiece from turning whilst the jack is adjusted. These screw jacks can be placed on other screw jacks (using a centering pad) to build up heights of up to 1370mm.

| Order No.          | $h_1$<br>min. | $h_1$<br>max. | $h_3$ | $h_4$ | $d_1$ | $d_2$ | $d_3$ | A/F | Static load<br>kN<br>max. | With locating pins 12x80<br>$h_2$ min. - $h_2$<br>max. | With locating pins 12x50<br>$h_2$ min. - $h_2$<br>max. | Weight<br>g |
|--------------------|---------------|---------------|-------|-------|-------|-------|-------|-----|---------------------------|--|--|-------------|
| <b>15220.W0007</b> | 65            | 85            | 22    | 16,5  | 50    | 34    | 12    | 46  | 30                        | 122 - 142  | 92 - 112   | 800         |
| <b>15220.W0011</b> | 85            | 125           | 22    | 16,5  | 50    | 34    | 12    | 46  | 30                        | 142 - 182  | 112 - 152  | 1000        |