

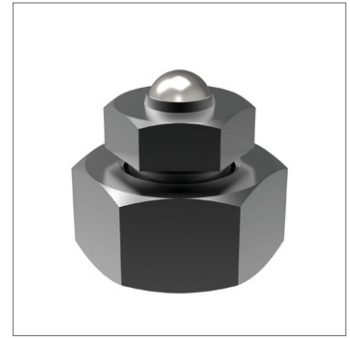

Height Setting Screw Jack with pivoting ball

Screw Jacks

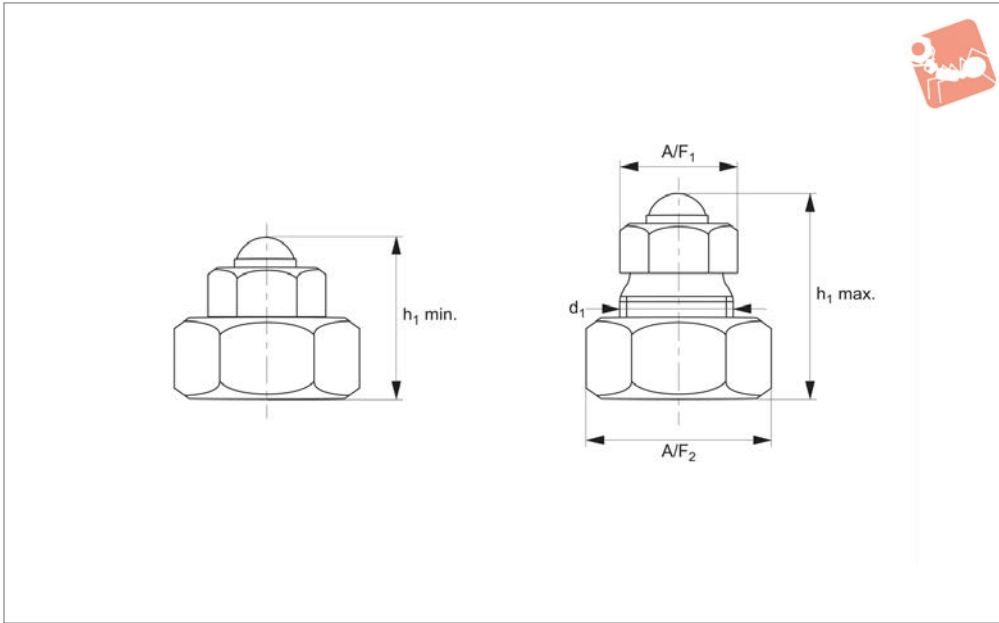

15520

SCREW JACKS

Material

Body: steel, tempered, burnished.
Ball: steel, hardened.

screw jack is designed to support and align cast iron or forged components. Alignment can be made to 0,1mm.

reduces the required operating forces. The use of a point-type support reduces the transmission of turning forces generated by the machine spindle.

Technical Notes

Used as a point support, this heavy-duty

Tips

The pivoting ball minimizes the friction and

Order No.	Size	h_1 min.	h_1 max.	d_1	A/F_1	A/F_2	Static load kN max.	Weight g
15520.W0070	70	56	70	39x3	41	60	30	950

