

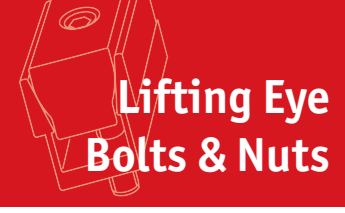

Steel Female Lifting Eye Bolts

inch sizes



Lifting Eye Bolts & Nuts

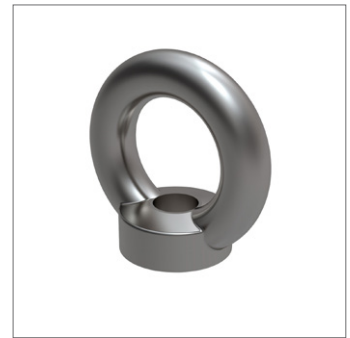
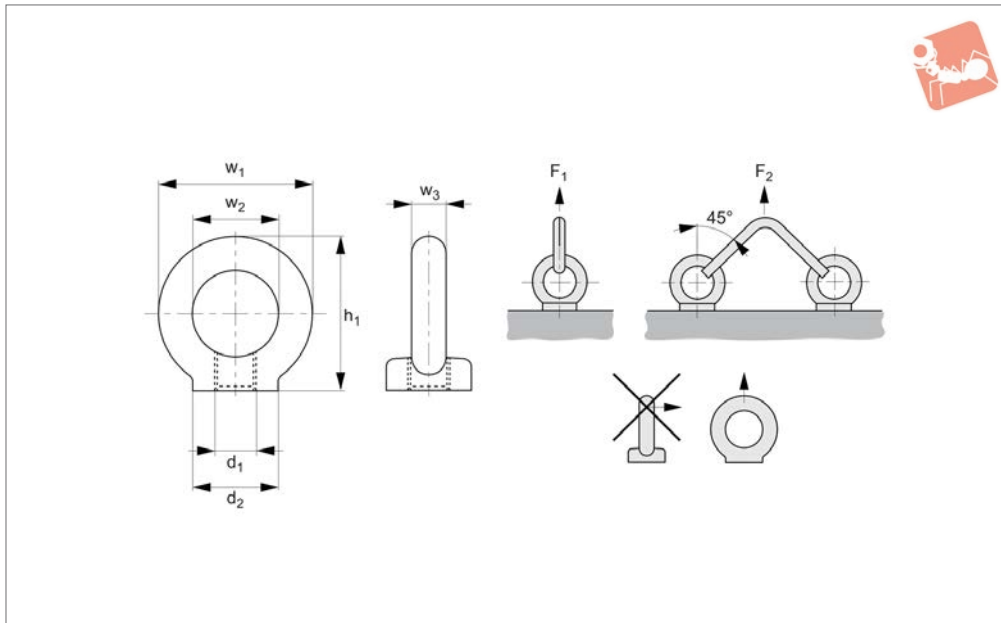

18846

LIFTING EYE BOLTS & NUTS

Material

Forged steel (C15E) annealed and zinc plated. Contact face machined. CE marked. Hot dipped galvanised versions (for more demanding applications and limited outside use) also available on request, suffix changes to -GV.

Technical Notes

To DIN 582.
When using lifting eye bolts it is critical to ensure that the face is in firm contact with the mating surface.

These lifting bolts are generally installed and remain on a piece of equipment for the purpose of transporting them. They are not for repeated lifting use - if this is required our swivelling lifting bolt range should be used.

Tips

Maximum load values are only applicable when the thread and the material, it is being used in is as least as strong as the that of the bolt.

F_1 and F_2 values given are for steel and cast iron components.

Important Notes

Not to be used at lift angles of greater than 45° or with swivelling loads.

Please refer to the safety documentation before using this part.
Supplied with certificate and operating instructions.

Order No.	d ₁	Thread type	d ₂	w ₁	h ₁	w ₂	w ₃	F ₁ kg max.	F ₂ kg max.	Weight kg
18846.W0025	1/4"-20	UNC	20	36	8	20	36	70	50	0.05
18846.W0038	3/8"-16	UNC	25	45	10	25	45	230	170	0.09
18846.W0050	1/2"-13	UNC	30	54	12	30	53	340	240	0.16
18846.W0063	5/8"-11	UNC	35	63	14	35	62	700	500	0.24
18846.W0075	3/4"-10	UNC	40	72	16	40	71	1200	830	0.36
18846.W0088	7/8"-9	UNC	50	90	20	50	90	1500	1050	0.72
18846.W0100	1"-8	UNC	50	90	20	50	90	1800	1270	0.72
18846.W0112	1-1/8"-7	UNC	65	108	24	60	109	2500	1650	1.32
18846.W0150	1-1/2"-6	UNC	85	144	32	80	147	6100	4300	3.11
18846.W0200	2"	UNC	100	166	38	90	168	9900	7300	5.02
18846.W0250	2-1/2"	UNC	120	206	48	110	208	16000	11000	9.30

