

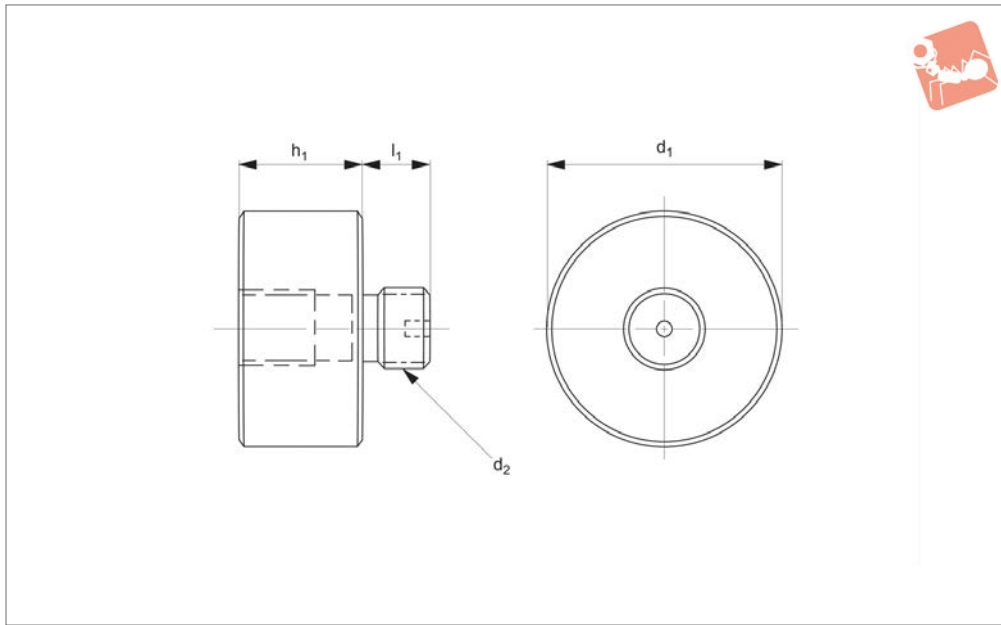

CMM Fixturing Stand offs

M 8 threads

Gauging & Inspection



19330

GAUGING & INSPECTION

Material

Carbon steel.

Important Notes

Provides resting point to raise part for probing.

Order No.	d ₁	d ₂	h ₁	l ₁	Weight g
19330.W1315	13	M 8	15	8	91
19330.W1320	13	M 8	20	8	136
19330.W1325	13	M 8	25	8	182
19330.W1350	13	M 8	50	8	364
19330.W1375	13	M 8	75	8	409
19330.W1915	19	M 8	15	8	136
19330.W1920	19	M 8	20	8	182
19330.W1925	19	M 8	25	8	227
19330.W1950	19	M 8	50	8	454
19330.W1975	19	M 8	75	8	591
19330.W2515	25	M 8	15	8	182
19330.W2520	25	M 8	20	8	227
19330.W2525	25	M 8	25	8	272
19330.W2550	25	M 8	50	8	500
19330.W2575	25	M 8	75	8	727



Wixroyd's CMM fixturing system is designed for easy assembly and high repeatability, eliminating the need to build dedicated fixtures. The system offers a highly accurate and flexible solution of holding parts while probing on CMMs.

Flexible

A variety of component parts as well as complete kits are available; to enable setup of fixtures in minutes.

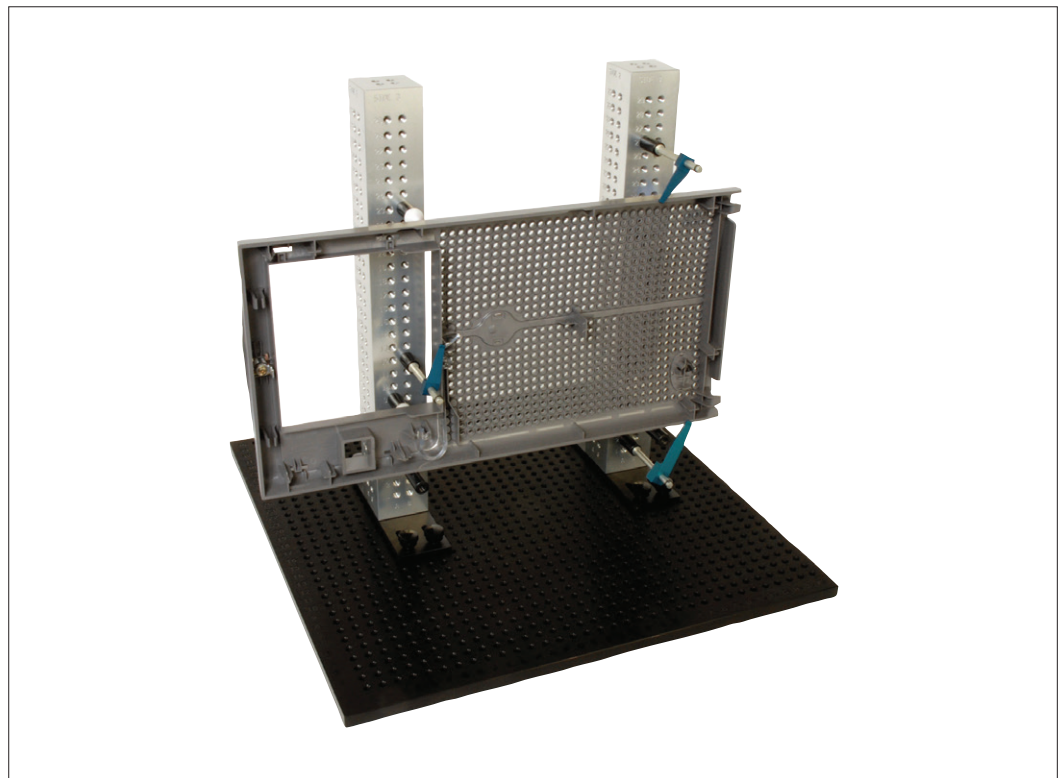
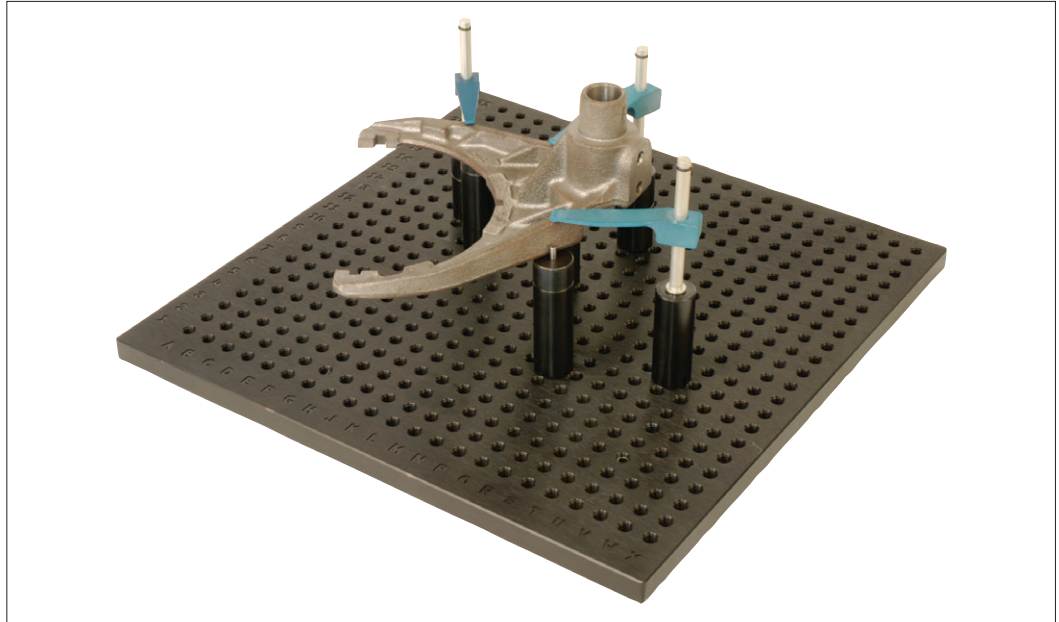

- Aluminium base plates – hole based system with alpha-numeric labelling for easy set-up and recording of fixture positions.
- Fixture towers – ideal for fixturing of large vertical components.
- Soft-touch clamps – non-marking clamps providing the ideal force for holding parts during CMM probing.
- Locating components – rest pads, vee pads for cylindrical parts, pin rests etc.