

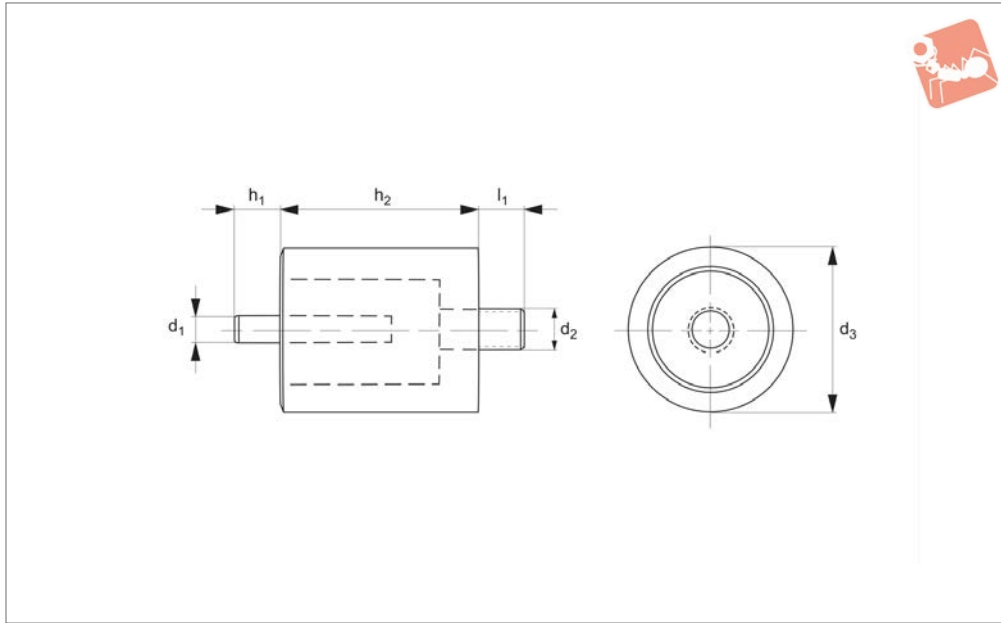

CMM Fixturing Magnetic Stand off with pin, for M 8 threads

Gauging & Inspection



19337

GAUGING & INSPECTION

Material

AL NICO magnet in brass sleeve.

Important Notes

For fixturing steel or iron parts. Magnetic force holds parts during probing.

Order No.	d ₁	d ₂	d ₃	h ₁	h ₂	l ₁
19337.W1325	3	M 8	12.7	6	25	8
19337.W1925	3	M 8	19.0	6	25	8
19337.W2525	3	M 8	25.4	6	25	8



Wixroyd's CMM fixturing system is designed for easy assembly and high repeatability, eliminating the need to build dedicated fixtures. The system offers a highly accurate and flexible solution of holding parts while probing on CMMs.

Flexible

A variety of component parts as well as complete kits are available; to enable setup of fixtures in minutes.

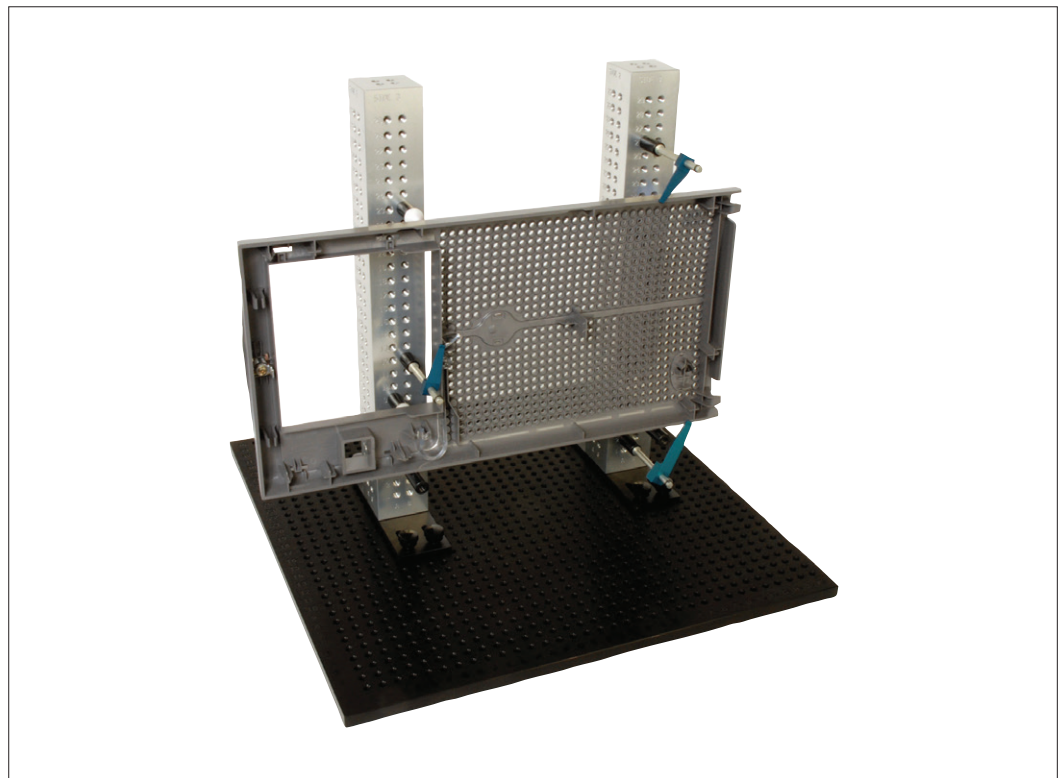
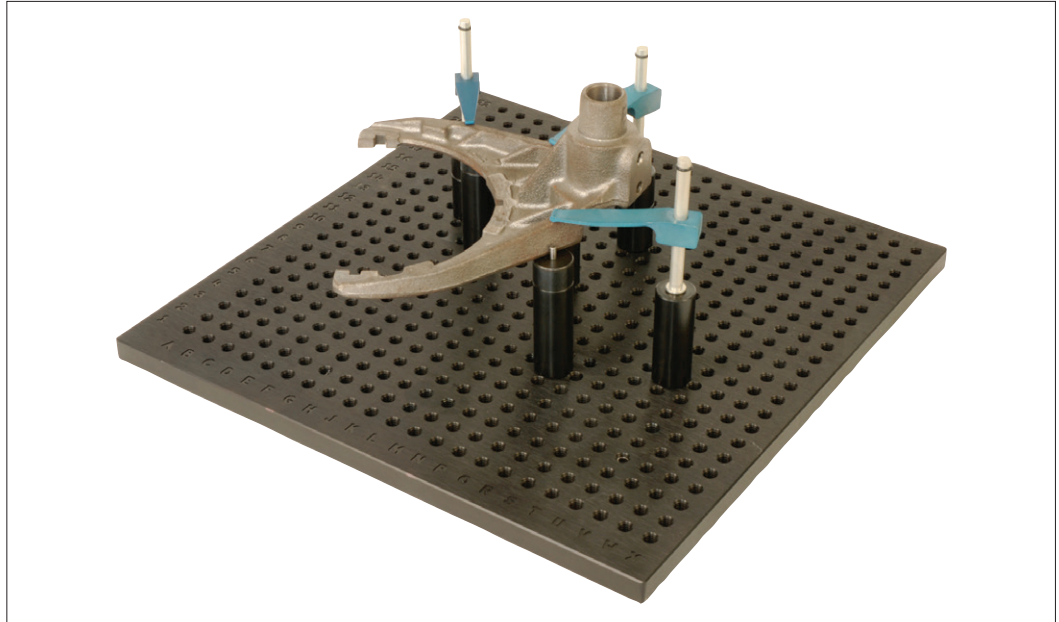

- Aluminium base plates – hole based system with alpha-numeric labelling for easy set-up and recording of fixture positions.
- Fixture towers – ideal for fixturing of large vertical components.
- Soft-touch clamps – non-marking clamps providing the ideal force for holding parts during CMM probing.
- Locating components – rest pads, vee pads for cylindrical parts, pin rests etc.