



Threaded Insert - Solid - Metric

carbon steel



Threaded Inserts

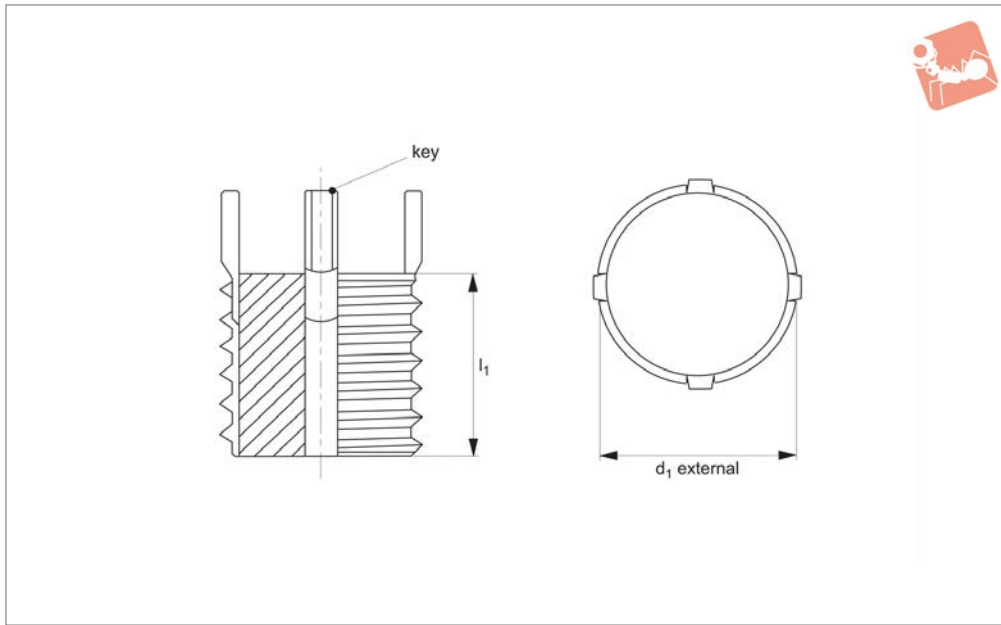

22040

THREADED INSERTS

Material

Inserts: carbon steel (C1215) or equivalent. Zinc phosphate.

Keys: stainless steel (302 CRES) or equivalent. Passivated.

Technical Notes

General tolerances:

± 0,25" unless specified.

Tap drill hole tolerances:

6,9 to 10,8 = +0,10/-0,025".

12,8 and over = +0,13/-0,025".

Tips

Order installation tool separately, as identified by „Inst. tool ref.“ in table.

Important Notes

Four locking keys on external threads M12 and over. Two locking keys on external

threads smaller than M12.

Installation (Inst.) drill size, countersink, thread tap and thread depth as specified in table.

Removal drill size and drill depth as specified in table.

External metric thread allows you to machine your internal thread.

Order No.	d ₁ tol. 6g	Thread type d ₁	l ₁	Inst. tool ref. 22052	Inst. tap drill size	Inst. c'sink dia. +0.25 -0.00	Inst. thread tap tol. 6H	Inst. thread depth min.	Removal drill size	Removal drill depth
22040.W0210	M 8x1,25	Coarse	8	.W0210	6,90	8,3	M 8x1,25	9,5	5,5	4,0
22040.W0220	M10x1,25	Fine	10	.W0220	8,80	10,3	M10x1,25	12,5	7,5	4,8
22040.W0230	M12x1,25	Fine	12	.W0230	10,80	12,3	M12x1,25	14,5	9,5	4,8
22040.W0240	M14x1,50	Fine	14	.W0240	12,80	14,3	M14x1,50	16,5	11,5	4,8
22040.W0250	M16x1,50	Fine	16	.W0250	14,75	16,3	M16x1,50	18,5	13,5	4,8
22040.W0260	M18x1,50	Fine	18	.W0260	16,75	18,3	M18x1,50	20,5	15,5	4,8
22040.W0270	M20x1,50	Fine	20	.W0270	18,75	20,3	M20x1,50	22,5	17,5	4,8
22040.W0280	M22x1,50	Fine	22	.W0280	20,50	22,3	M22x1,50	24,5	17,8	6,4
22040.W0290	M24x1,50	Fine	24	.W0290	22,50	24,3	M24x1,50	26,5	19,8	6,4
22040.W0300	M30x2,00	Fine	30	.W0300	28,00	30,3	M30x2,00	34,5	25,8	6,4
22040.W0310	M32x2,00	Non-Std	32	.W0310	30,00	32,3	M32x2,00	36,5	27,8	6,4
22040.W0320	M33x2,00	Non-Std	33	.W0320	31,00	33,3	M33x2,00	37,5	28,8	6,4



Threaded inserts are used to quickly repair stripped, damaged or worn out threads with new stronger threads, or are used in original equipment to guarantee stronger thread connections.

Wixroyd inserts are easy to install and remove, without the need for special drills, taps or pre-winder tools. The 'locking keys' on threaded inserts are easily driven down into the thread of the surrounding base material – locking the insert securely in place.



Carbon steel inserts



Stainless steel inserts



Solid inserts

Key Features

- Solid, one-piece construction providing high pull-out strengths.
- Locking "keys" provide a positive mechanical lock against rotation of the insert.
- Easy installation and removal.
- Installation with standard drills and taps.
- No pre-winder tools required.
- No tangs to break off and account for in the assembly.
- For use in a wide variety of materials.
- Both metric and imperial sizes available in coarse and fine pitches.

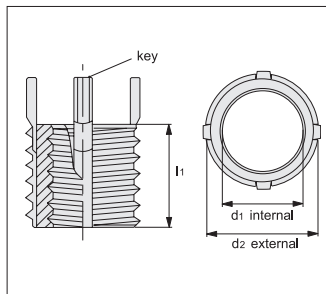

Installation and Removal

Installation

- 1 Select desired threaded insert, and from the product data table identify the installation drill and tap sizes (note the drill is slightly oversized deliberately). Drill with standard tap drill as per product data table, and countersink with standard 82-100° countersink.
- 2 Tap new threads with standard tap – as specified in product data table.
- 3 Screw in the insert until it is 0.25 to 0.75mm (0.010 to 0.030 inch) below the surface.
- 4 Drive locking keys down with several hammer taps on the installation tool – see product data table for correct tool.
- 5 Insert is installed.

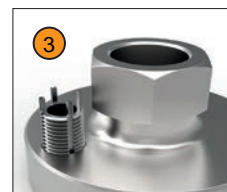

Removal

Wixroyd threaded inserts, can be removed (if required) without damage to the surrounding material.

- 1 Refer to product data tables to identify the drill size and drill depth required for removal. Drill out the material between the insert keys and the internal thread to specified depth.
- 2 Bend the locking keys inward and break off.
- 3 Remove the old insert using a screw extractor.
- 4 Install a replacement insert into the original tapped hole.

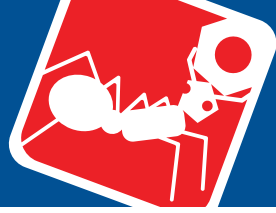

Threaded Inserts

overview

22000 - 22064

Fixing Elements

Stainless Steel



22000 - Thinwall - Metric
Use installation tool
no. 22060.



22002 - Heavy Duty -
Metric.
Use installation tool
no. 22062.



22012 - Heavy Duty -
Metric - Inch.
Use installation tool
no. 22064.



22020, 22022, 22024 - Inch
- Thinwall - Heavy Duty -
Extra Heavy Duty.
Use installation tool
no. 22054-58.

Carbon Steel



22004 - Thinwall - Metric
Use installation tool
no. 22060.



22006 - Heavy Duty -
Metric
Use installation tool
no. 22062.



22010 - Heavy Duty -
Metric - Inch.
Use installation tool
no. 22064.



22030 - 22034 - Inch
- Thinwall - Heavy Duty -
Extra Heavy Duty
Use installation tool
no. 22054, 20058.

Solid



22040 - Metric - Carbon
Use installation tool
no. 22052.



22042 - Metric -
Stainless Steel
Use installation tool
no. 22052.



22044 - Inch - Carbon
Use installation tool
no. 22050.



22046 - Inch - Stainless
Steel
Use installation tool
no. 22050.

Installation Tools



22050 for 22044 & 22046



22052 for 22040 & 22042



22054, 22058 for 22020,
22024, 22030, 22034,



22060 for 22000 & 22004



22062 for 22002 & 22006



22064 for 22010 & 22012

THREADED INSERTS

ov-W22000-AP0084.1-W22064-A-TTR1760-threaded-inserts-overview-rnh- Updated - 26-10-2022