

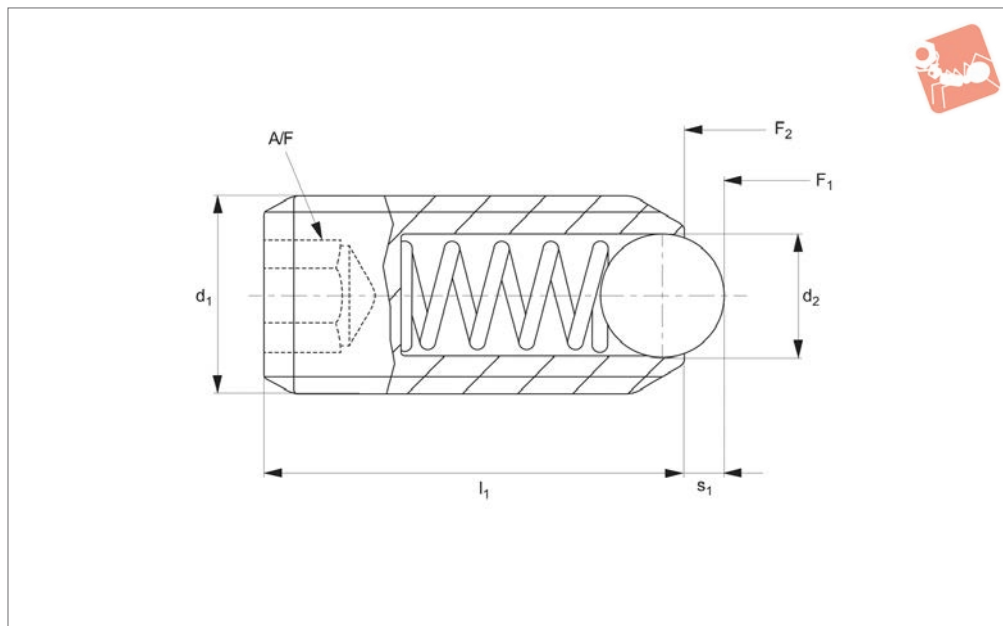

Spring Plungers with ball end & hex. socket



31500

SERIES

Material

Free cutting steel type-

Body: free cutting steel, blackened. Ball: ball bearing steel 1.3505 (100Cr6) hardened. Spring: stainless steel.

Stainless steel type-

Body: stainless steel 1.4305 (AISI 303). Ball: stainless steel 1.3505 (100Cr6), hardened. Spring: stainless steel.

Technical Notes

These spring plungers may be used for

location, for applying pressure or lifting off.

Temperature range max. 250° C.

Spring load * = statistical average value.

For calculation of indexing resistance please refer to spring plunger technical pages.

Tips

Spring load identifier:

Normal spring load - no marking.

Increased spring load - body marked with two lines.

Special types available on request.

Important Notes

All metric Wixroyd spring plungers have a coarse thread, see appendix five for thread details.

Order No.	Material	Spring load	d ₁	d ₂	l ₁	Spring load F ₁ N ≈	Spring load F ₂ N ≈	Stroke s ₁	A/F	Weight g
31500.W0204	Stainless	Normal	M 4	2.5	12	8.5	14.0	0.8	2.0	0.7
31500.W0203	Stainless	Normal	M 3	1.5	8	3.0	4.5	0.4	1.5	0.3
31500.W0205	Stainless	Normal	M 5	3.0	14	8.0	14.0	0.9	2.5	1.2
31500.W0206	Stainless	Normal	M 6	3.5	15	11.0	18.0	1.0	3.0	1.8
31500.W0208	Stainless	Normal	M 8	4.5	18	18.0	31.0	1.5	4.0	3.9
31500.W0210	Stainless	Normal	M10	6.0	23	24.0	45.0	2.0	5.0	8.1
31500.W0212	Stainless	Normal	M12	8.0	26	26.0	49.0	2.5	6.0	13.0
31500.W0216	Stainless	Normal	M16	10.0	33	41.0	86.0	3.5	8.0	32.0
31500.W0220	Stainless	Normal	M20	12.0	43	56.0	111.0	4.5	10.0	66.0
31500.W0224	Stainless	Normal	M24	15.0	48	81.0	151.0	5.5	12.0	106.0
31500.W0243	Stainless	Increased	M 3	1.5	8	5.0	9.0	0.4	1.5	0.3
31500.W0244	Stainless	Increased	M 4	2.5	12	12.0	18.0	0.8	2.0	0.6
31500.W0245	Stainless	Increased	M 5	3.0	14	15.0	22.0	0.9	2.5	1.2
31500.W0246	Stainless	Increased	M 6	3.5	15	19.0	28.0	1.0	3.0	1.9
31500.W0248	Stainless	Increased	M 8	4.5	18	36.0	62.0	1.5	4.0	4.2
31500.W0250	Stainless	Increased	M10	6.0	23	57.0	104.0	2.0	5.0	8.2
31500.W0252	Stainless	Increased	M12	8.0	26	61.0	110.0	2.5	6.0	13.0
31500.W0256	Stainless	Increased	M16	10.0	33	68.0	142.0	3.5	8.0	33.0
31500.W0260	Stainless	Increased	M20	12.0	43	84.0	166.0	4.5	10.0	66.0
31500.W0264	Stainless	Increased	M24	15.0	48	127.0	237.0	5.5	12.0	107.0
31500.W0004	Steel	Normal	M 4	2.5	12	8.5	14.0	0.8	2.0	0.7
31500.W0003	Steel	Normal	M 3	1.5	8	3.0	4.5	0.4	1.5	0.3
31500.W0005	Steel	Normal	M 5	3.0	14	8.0	14.0	0.9	2.5	1.2

Spring Plungers

with ball end & hex. socket



SERIES

Order No.	Material	Spring load	d ₁	d ₂	l ₁	Spring load F ₁ N ≈	Spring load F ₂ N ≈	Stroke s ₁	A/F	Weight g
31500.W0006	Steel	Normal	M 6	3.5	15	11.0	18.0	1.0	3.0	1.8
31500.W0008	Steel	Normal	M 8	4.5	18	18.0	31.0	1.5	4.0	3.9
31500.W0010	Steel	Normal	M10	6.0	23	24.0	45.0	2.0	5.0	8.1
31500.W0012	Steel	Normal	M12	8.0	26	26.0	49.0	2.5	6.0	13.0
31500.W0016	Steel	Normal	M16	10.0	33	41.0	86.0	3.5	8.0	32.0
31500.W0020	Steel	Normal	M20	12.0	43	56.0	111.0	4.5	10.0	66.0
31500.W0024	Steel	Normal	M24	15.0	48	81.0	151.0	5.5	12.0	106.0
31500.W0043	Steel	Increased	M 3	1.5	8	5.0	9.0	0.4	1.5	0.3
31500.W0044	Steel	Increased	M 4	2.5	12	12.0	18.0	0.8	2.0	0.6
31500.W0045	Steel	Increased	M 5	3.0	14	15.0	22.0	0.9	2.5	1.2
31500.W0046	Steel	Increased	M 6	3.5	15	19.0	28.0	1.0	3.0	1.9
31500.W0048	Steel	Increased	M 8	4.5	18	36.0	62.0	1.5	4.0	4.2
31500.W0050	Steel	Increased	M10	6.0	23	57.0	104.0	2.0	5.0	8.2
31500.W0052	Steel	Increased	M12	8.0	26	61.0	110.0	2.5	6.0	13.0
31500.W0056	Steel	Increased	M16	10.0	33	68.0	142.0	3.5	8.0	33.0
31500.W0060	Steel	Increased	M20	12.0	43	84.0	166.0	4.5	10.0	66.0
31500.W0064	Steel	Increased	M24	15.0	48	127.0	237.0	5.5	12.0	107.0



Wixroyd Spring Plungers

Wixroyd Spring Plungers - A Range of Endless Possibilities

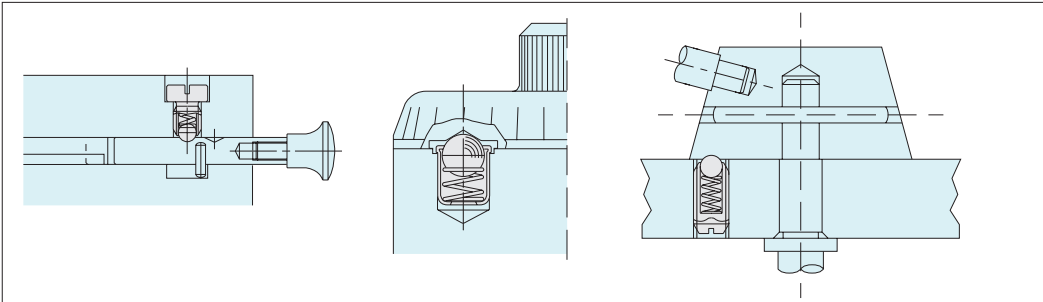

Made of high quality steel and stainless steel, Wixroyd's Spring Plunger range is proven to be reliable for millions of repetitions in securing, positioning, positive locking, indexing and quick release. Their application is limited only by the imagination!

Three push-fit spring plungers no. 32000 have been added to the design of this recessed commercial light fitting. The push-fit design of the plunger makes for easy assembly during production. Their use greatly simplifies the mounting and servicing of the units, reducing handling costs and saving valuable operator time.

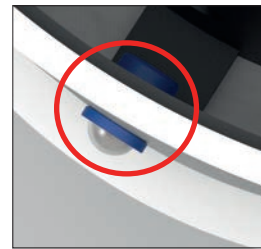

Commercial Lighting

Used in conjunction with a simple hinge, Wixroyd spring plunger 32300 provides an easy and secure means to positively position and secure the back panel of a blood gas analysis machine. With both brass and stainless steel varieties, our spring plungers have a wide range of application in the medical, pharmaceutical, food and drink processing industries.

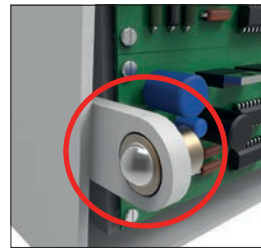

Medical Applications

Uses

- For location, applying pressure and "lifting off".
- Securing and positioning.
- Positive locking and indexing.
- Quick release.

Industry Sectors

- Machine and fixture design.
- Measuring equipment.
- Electronic components.
- Lighting equipment.
- Medical, optics and orthopaedics.

Applications

Wixroyd Spring Plungers - Uses and Mounting Options

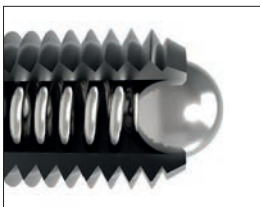

- 31400
- 31420
- 31500
- 32000
- 32100
- 32102
- 32280
- 32300
- 32302
- 32350

Mounting Options

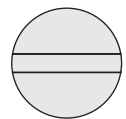

Rear slot

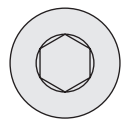

Rear hexagon

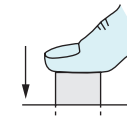

Push fit

Ball Type

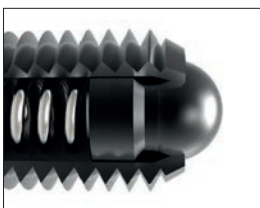

- 31000
- 31600
- 32150
- 32200
- 32220
- 32282
- 32400
- 32420

Mounting Options

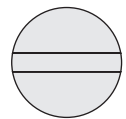

Rear slot

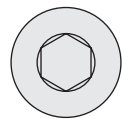

Rear hexagon

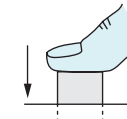

Push fit

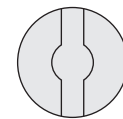

Front slot

Pin Head Type

Wixroyd Spring Plungers

quality products



Quality products every time

100% Testing

- Every spring plunger that is produced on the Wixroyd assembly line is individually tested. That is how we guarantee the quality of our products.
- A Wixroyd spring plunger is tested against four key criteria during manufacture.

Accuracy of 'S' Stroke/ Spring Range



Accuracy of f_1 and f_2 Spring Forces



Accuracy of Ball Diameter

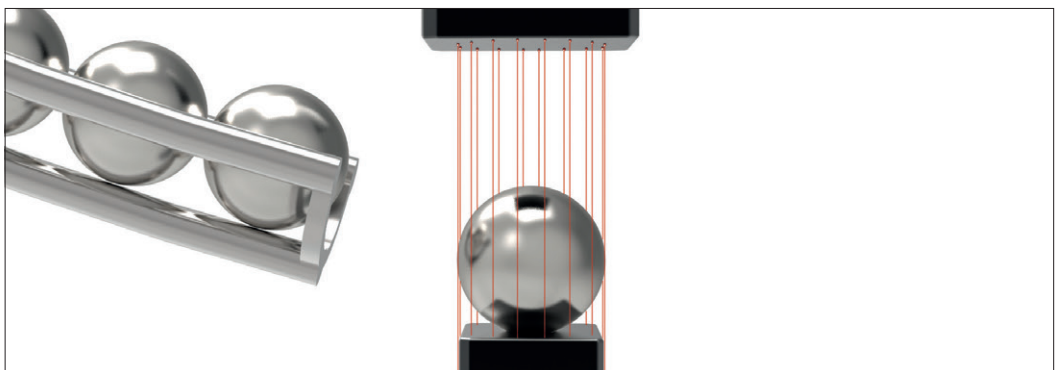

Accuracy of Thread

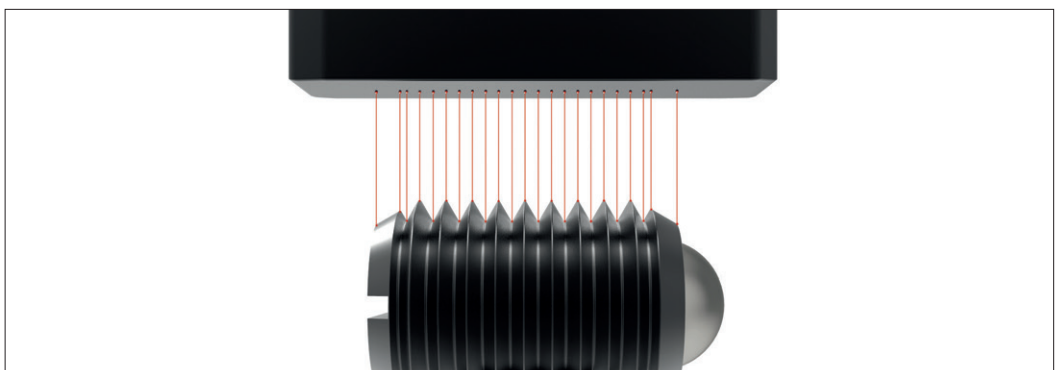

SERIES



Wixroyd Spring Plungers

metric thread

ISO metric coarse threads (mm)

Thread (D)	3	3,5	4	4,5	5	6	7	8	10	12	14	16	18	20	22	24
Pitch	0,5	0,6	0,7	0,75	0,8	1,0	1,0	1,25	1,5	1,75	2,00	2,0	2,5	2,5	2,5	3,0

Thread Details

All Wixroyd metric spring plungers have a coarse thread.

Spring Loads

Typical Spring Repetitions

Calculating Indexing Resistance

Electrical Conductivity

Specials to Your Own Design

- s** Stroke, or movement of plunger's ball or pin.
- f₁** The force required in Newtons (N) to overcome the static strength of the spring and achieve initial movement of the plunger's ball or pin.
- f₂** The force required in Newtons (N) to fully compress the spring until the ball or pin is fully depressed against the plunger's body.

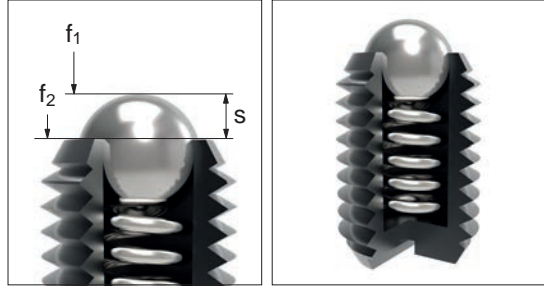

Although dependent upon a number of application specific factors, we are able to give the following guide relating to the maximum number of spring repetitions or cycles of our spring plungers.

- 100% or full stroke "s" used: approx. 300,000 cycles.
- 65% of stroke "s" used: approx 10,000,000 cycles.

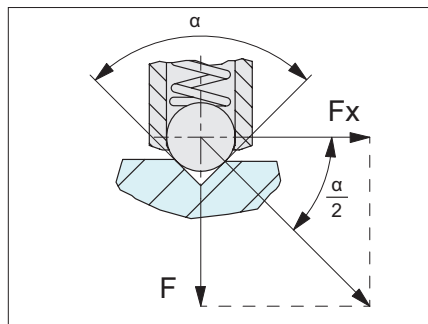
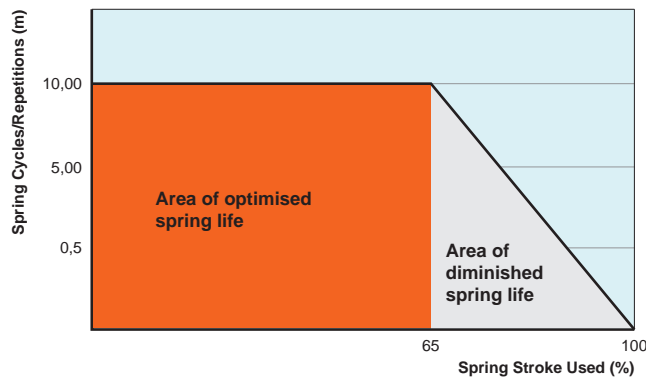

We are able to provide the following formula as an approximation of the pull or push force (N) required to 'release' a ball plunger from its indexing counterpart.

$$F_x = \frac{F}{\tan \frac{\alpha}{2}}$$

F_x = pull or push force (N)
 F = plungers spring force (see relevant product table)
 α = angle of the indexing counterpart face

For example:

For Spring plunger 31500.W0010;
 $F = 24\text{N}$ (see product table)

If $\alpha = 90^\circ$

$$F_x = \frac{24}{\tan \frac{90}{2}} = 24\text{N}$$

If $\alpha = 60^\circ$

$$F_x = \frac{24}{\tan \frac{60}{2}} = 41,5\text{N}$$

If $\alpha = 120^\circ$

$$F_x = \frac{24}{\tan \frac{120}{2}} = 13,8\text{N}$$

Important Note: This is only an approximation formula. For more accurate calculation the roughness of the counterpart surface as well as any variation in the plungers spring force (due to age or high repetitions) should be considered.

We are often asked the electrical conductivity of our spring plungers, unfortunately we are unable to provide any reliable information related to this as there are many factors in an application. We recommend you study the specific material properties of the spring plunger's component parts to make your own calculations, alternatively if in doubt make a test application.

Manufacturing exactly to your specific requirements is also our strength. If you need a variation in spring pressure, plunger body or pin design we can assist with a special design item for volumes as low as 1,000 units.

For further information, or to request a quotation, please call our sales office on 0333 207 4497.