

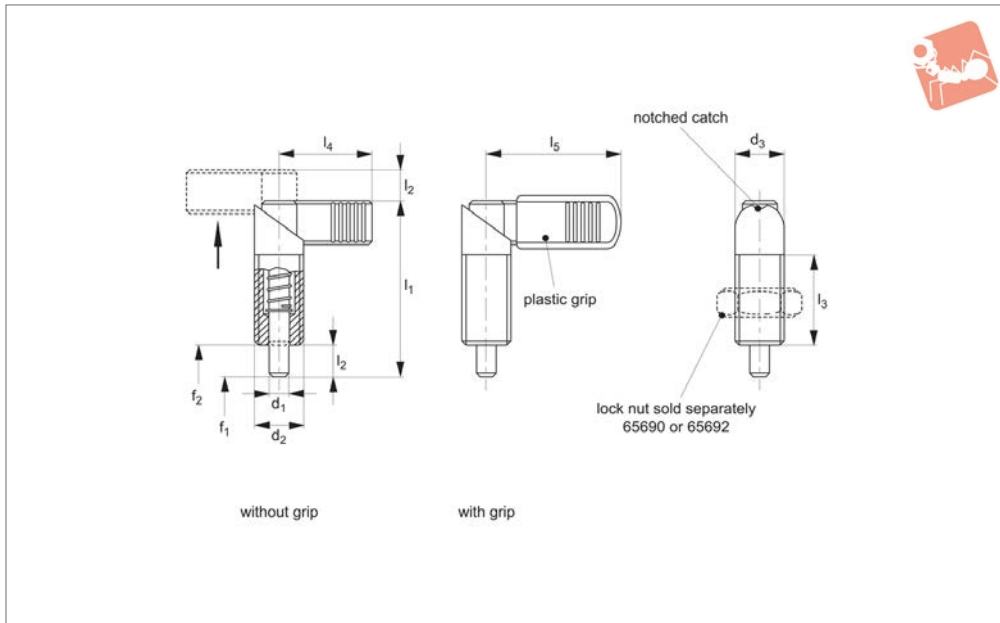

Index Plungers - Lever Grip

locking - steel

Index Plunger & Pins



32500

INDEX PLUNGER & PINS

Material

Body: free-cutting steel, blackened.

Pin: hardened steel.

Plastic grip: thermoplastic, black, dull.

Technical Notes

Turn lever 180° to retract pin. To enable

pin to be held in retracted position, secure lever in notched catch on plunger body.

Plastic grip type, improves handling.

Temperature resistance of type with plastic grip is -30°C to +80°C

Lock nuts sold separately. See products 65690 and 65692

Tips

Spring loads * = statistical average.

Order No.	Type	d_1 -0.02 -0.04	d_2	d_3	l_1 ≈	l_2 min.	l_3 +1.5	l_4	l_5	Spring load F_1 N ≈	Spring load F_2 N	Weight g
32500.W0000	Without Grip	4	M10x1,0	10	37.5	6	19	21	-	8.5	25.0	17.0
32500.W0001	Without Grip	5	M10x1,0	10	37.5	6	19	21	-	8.5	25.0	18.0
32500.W0002	Without Grip	6	M10x1,0	10	37.5	6	19	21	-	8.5	25.0	18.0
32500.W0003	Without Grip	5	M12x1,5	12	47.0	8	26	26	-	8.5	19.5	29.0
32500.W0004	Without Grip	6	M12x1,5	12	47.0	8	26	26	-	8.5	19.5	29.0
32500.W0006	Without Grip	6	M16x1,5	16	56.0	10	30	32	-	11.5	30.5	59.0
32500.W0005	Without Grip	8	M12x1,5	12	47.0	8	26	26	-	8.5	19.5	30.0
32500.W0007	Without Grip	8	M16x1,5	16	56.0	10	30	32	-	11.5	30.5	61.0
32500.W0008	Without Grip	8	M20x1,5	20	69.0	12	36	37	-	21.0	57.5	121.0
32500.W0009	Without Grip	10	M16x1,5	16	56.0	10	30	32	-	11.5	30.5	64.0
32500.W0010	Without Grip	10	M20x1,5	20	69.0	12	36	37	-	21.0	57.5	123.0
32500.W0012	Without Grip	12	M20x1,5	20	69.0	12	36	37	-	21.0	57.5	127.0
32500.W0353	With Grip	5	M12x1,5	12	47.0	8	26	-	32	8.5	19.5	30.0
32500.W0354	With Grip	6	M12x1,5	12	47.0	8	26	-	32	8.5	19.5	30.0
32500.W0356	With Grip	6	M16x1,5	16	56.0	10	30	-	42	11.5	30.5	61.0
32500.W0355	With Grip	8	M12x1,5	12	47.0	8	26	-	32	8.5	19.5	32.0
32500.W0357	With Grip	8	M16x1,5	16	56.0	10	30	-	42	11.5	30.5	63.0
32500.W0358	With Grip	8	M20x1,5	20	69.0	12	36	-	52	21.0	57.5	124.0
32500.W0359	With Grip	10	M16x1,5	16	56.0	10	30	-	42	11.5	30.5	66.0
32500.W0360	With Grip	10	M20x1,5	20	69.0	12	36	-	52	21.0	57.5	128.0
32500.W0362	With Grip	12	M20x1,5	20	69.0	12	36	-	52	21.0	57.5	131.0

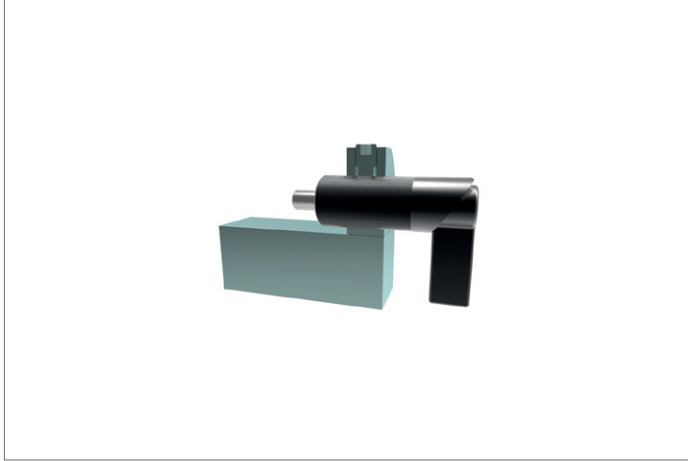



A Wide Selection of Solutions

- Locating and positioning.
- Indexing.
- Securing.
- Positive locking.
- Rapid adjustment of all kinds of tables, platforms and fixtures.
- Machine and fixture design.
- OEM products.
- Sports equipment.
- Medical aides (wheelchairs etc.).
- Aerospace.
- Machine cabinets.

Applications

Materials

Locking or Non Locking

Handling and Actuation Methods

Mounting Options

Additional Technical Notes

Spring Loads



Steel with plastic grip



Stainless with plastic grip



Stainless body and grip



Locking (park)



Non locking (spring back)



Push pull



Standard grip



Lever grip



T-handle



Pull ring



Threaded for bespoke handle



Fine threaded (standard)



Coarse thread



Flange mount



Thin wall mount



Weldable

- Unless otherwise stated, grips on index plungers are not removable.
- Many of the pins on index plungers are toleranced to either the pin or the hole. Please refer to the specific product table.
- Index plungers are not recommended for shear load applications.

	Pin Tol.	Hole Tol.
①	h_9	+0,03 +0,08
②	-0,02 -0,04	H_7

s Stroke, or movement of plunger's pin.

f₁ The force required in Newtons (N) to overcome the static strength of the spring and achieve initial movement of the plunger's pin.

f₂ The force required in Newtons (N) to fully compress the spring until the pin is fully depressed against the plunger's body.

