

# Index Plungers - Pull Grip

mini - for thin walled parts - extra fine thread

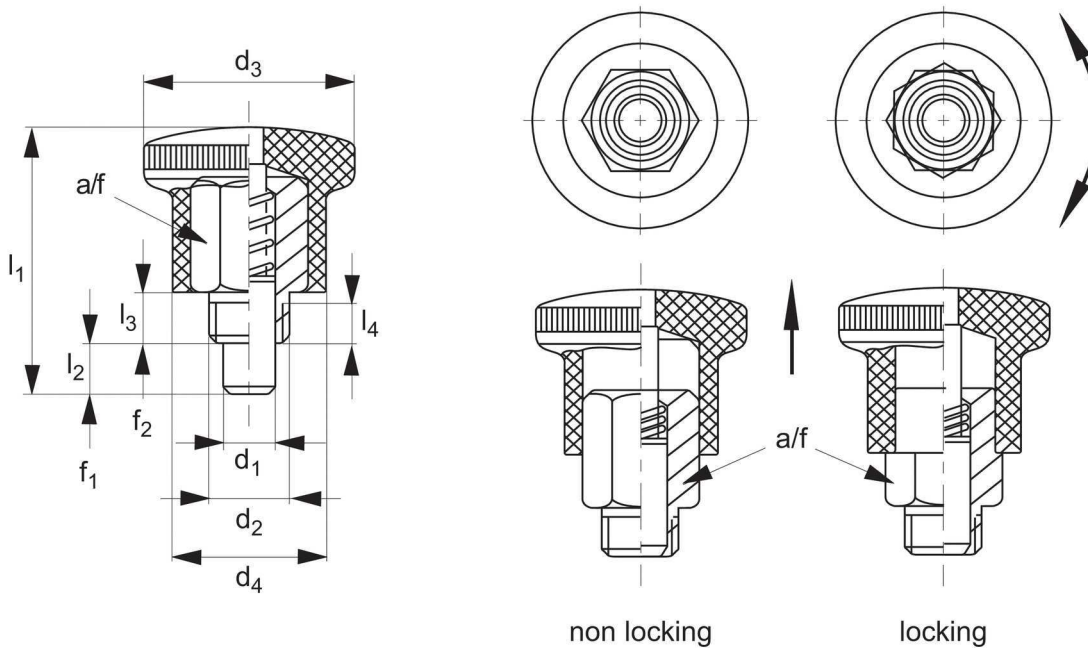

# 32600



Order No. Steel	Order No. Stainless	Type	d <sub>1</sub> 0 -0,0 6	d <sub>2</sub>	d <sub>3</sub>	d <sub>4</sub>	l <sub>1</sub>	l <sub>2</sub> min	l <sub>3</sub>	l <sub>4</sub> min	a/f	Spring	Spring	g
												load*	load*	
32600.W0024	32600.W0224	Non Locking	4	M 8x0,75	21	15	26,5	5	5	3,5	10	4,5	12	14
32600.W0026	32600.W0226	Non Locking	5	M 8x0,75	21	15	26,5	5	5	3,5	10	4,5	12	14
32600.W0028	32600.W0228	Non Locking	6	M10x1,00	25	18	34,0	7	7	4,5	12	5,0	18	25
32600.W0030	32600.W0230	Non Locking	7	M10x1,00	25	18	34,0	7	7	4,5	12	5,0	18	26
32600.W0034	32600.W0234	Locking	4	M 8x0,75	21	15	26,5	5	5	3,5	10	4,5	12	13
32600.W0036	32600.W0236	Locking	5	M 8x0,75	21	15	26,5	5	5	3,5	10	4,5	12	14
32600.W0038	32600.W0238	Locking	6	M10x1,00	25	18	34,0	7	7	4,5	12	5,0	18	24
32600.W0040	32600.W0240	Locking	7	M10x1,00	25	18	34,0	7	7	4,5	12	5,0	18	25

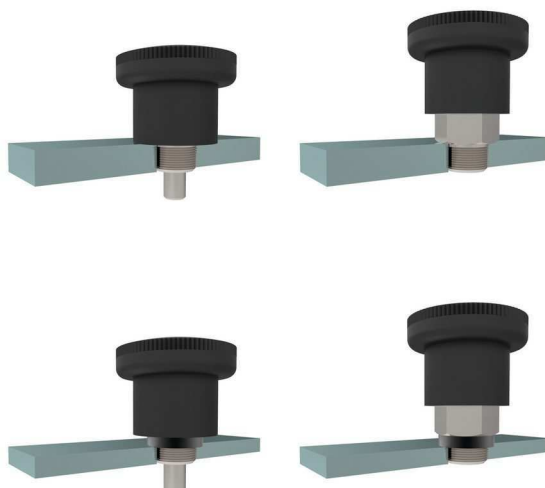

### Material

**Free cutting steel type-**  
Body: free cutting steel, galvanized.  
Pin: stainless steel 1.4305 (AISI 303).  
Grip: thermoplastic PA 6, black.

**Stainless steel type-**  
Body: stainless steel 1.4305 (AISI 303).  
Pin: stainless steel 1.4305 (AISI 303).  
Grip: thermoplastic PA 6, black.

### Technical Notes

**"Locking" type-** enable pin to be held in retracted/non-projecting position; pull back grip, turn 90° to engage 'locking' on a notched catch.

**"Non Locking" type-** pin simply springs back when grip released.

For positioning and indexing in the smallest of spaces. Particularly suited for use on sheet metal assemblies; e.g shopfitting displays, electrical cabinets and enclosures etc.

### Extra fine thread

Temperature resistance from -30° to +80°C.  
Distance collars no. 32750 can be used to adapt screw length.

### Tips

Grip non-removable.  
Spring loads \* = statistical average.





## A wide selection of solutions

- Locating and positioning.
- Indexing.
- Securing.
- Positive locking.
- Rapid adjustment of all kinds of tables, platforms and fixtures.
- Machine and fixture design.
- OEM products.
- Sports equipment.
- Medical aides (wheelchairs etc.).
- Aerospace.
- Machine cabinets.

## Applications



Steel with plastic grip

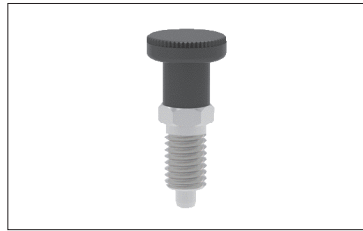

Stainless with plastic grip

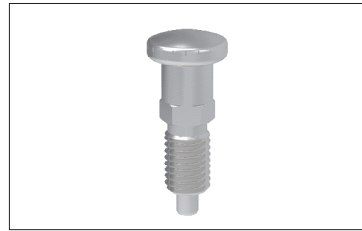

Stainless body and grip

## Materials



Locking (park)



Non locking (spring back)

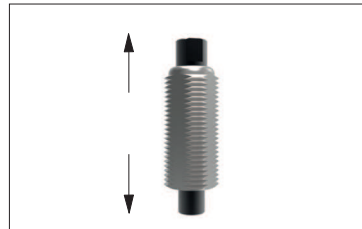

Push pull

## Locking or non locking



Standard grip



Lever grip



T-handle



Pull ring



Threaded for bespoke handle

## Handling and actuation methods



Fine threaded (standard)



Coarse thread



Flange mount



Thin wall mount



Weldable

## Mounting options

- Unless otherwise stated, grips on index plungers are not removeable.
- Many of the pins on index plungers are toleranced to either the pin or the hole. Please refer to the specific product table.
- Index plungers are not recommended for shear load applications.

### Pin Tol. Hole Tol.

①	$h_9$	+0,03 +0,08
②	-0,02 -0,04	H <sub>7</sub>

## Additional technical notes

- s** Stroke, or movement of plunger's pin.
- f<sub>1</sub>** The force required in Newtons (N) to over come the static strength of the spring and achieve initial movement of the plunger's pin.
- f<sub>2</sub>** The force required in Newtons (N) to fully compress the spring until the pin is fully depressed against the plunger's body.

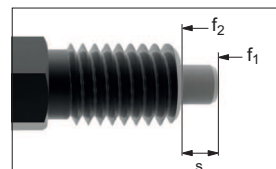

## Spring loads

# Computing the strength of index plungers

for shear loads / flexure loads of the plunger pin



## Flexure loads

As soon as a gap  $l$  exists between the mounting plate in which the index plunger is installed, and the mating or base plate, the load must be considered to be as per a flexure load, with rod clamped at one side.

With this approach, the calculation is made against the bending of the index plunger.

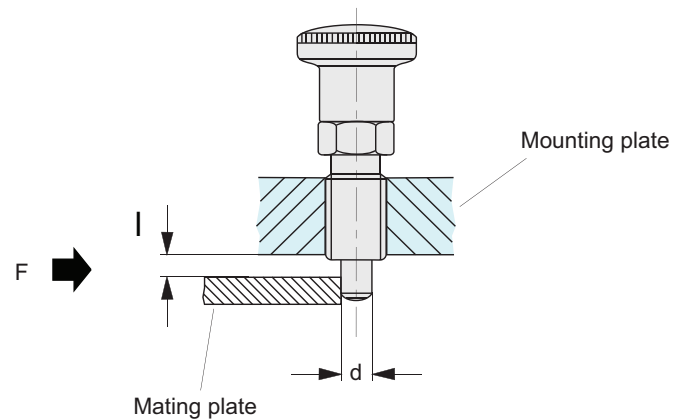

## Formulas for computation

### Resistance torque

$$W = \frac{\pi \times d^3}{32}$$

### Flexural stress

$$M_b = \sigma_b \times W$$

### Flexural strength

$$F = \frac{M_b}{l} = \frac{\sigma_b \times \pi \times d^3}{l \times 32}$$

## Material characteristics

The yield or substitute yield limit ( $R_e / R_p 0,2$ ) shown in the table opposite has been determined in tension tests involving tension specimen in accordance with DIN 50125-B6-30.

These tests constitute the basis for the load bearing details given.

Material Description	Material no.	$R_e$ in N/mm <sup>2</sup> (= per. flexural tension $\sigma_b$ )
C45Pb	1.0504	560
X 10 CrNiS 18 9A	ISI 303	580

## Calculation example, load values

Example:

Index plungers with a bolt diameter of 5 mm made of steel with a yield limit of  $R_e = 560 \text{ N/mm}^2$ , calculation against permanent deformation, the maximum permissible flexural strength is calculated as:

$$F_{\text{per}} = \frac{560 \text{ N/mm}^2 \times \pi \times (5\text{mm})^3}{2\text{mm} \times 32} = 3430 \text{ N}$$

d Bolt diameter	max. flexural strength $F$ in N, acc. to material and gap $l$ differentiated			
	C45Pb/1.0504		X 10 CrNiS 18 9/1.4305	
	$l = 2 \text{ mm}$	$l = 3 \text{ mm}$	$l = 2 \text{ mm}$	$l = 3 \text{ mm}$
3	740	490	760	510
4	1750	1170	1820	1210
5	3430	2290	3550	2370
6.5	930	3950	6140	4100
8	14070	9380	14570	9710
10	27480	18320	28470	18980
12	47490	31660	49190	32790
16	90070	102940	93290	119020

## Safety information

On principle, the design also needs an adequate safety coefficient to be taken into account. The usual safety coefficients under static load 1.2 to 1.5; pulsating 1.8 to 2.4 and alternating 3 to 4.

Disclaimer:

You should carry out your own test series to verify whether a certain product is suitable for your specific applications.

# Computing the strength of index plungers

for shear loads / flexure loads of the plunger pin



## Shear loads

Providing only a very small gap exists between the mounting plate in which the index plunger is installed, and the mounting plate or base plate, the load can be calculated as a clean shear action.

As this is normally not the case, the "flexure" load should be used - see following page.

Approximately 80 % of the bolt's tensile strength is assumed for the shear strength. This approach calculates against the tensile strength  $R_m$ , i.e. against the index pin shearing off.

To ensure the permanent and proper function of the index plunger, the yield limit  $R_e$  must be considered in place of the tensile strength  $R_m$ .

Stop using the index plunger if the pin is damaged or deformed.

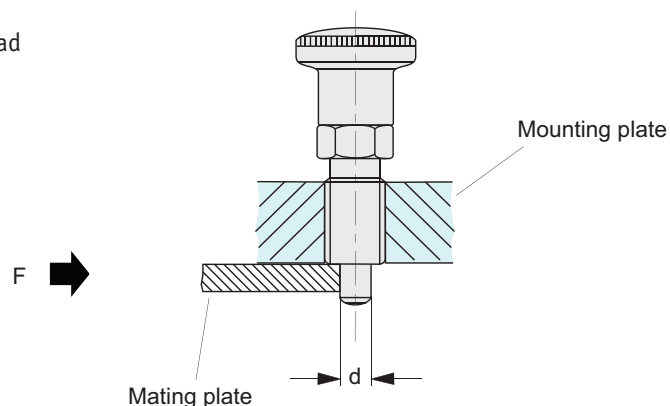

## Formulas for computation

### Bolt cross-section

$$S = \frac{d^2 \times \pi}{4}$$

### Limit tension

$$\tau_a = 0,8 \times R_m$$

### Shear force

$$F = S \times \tau_a = \frac{d^2 \times \pi}{4} \times 0,8 \times R_m$$

## Material characteristics

The tensile strength shown in the table opposite ( $R_m$ ) and the yield or substitute yield limit ( $R_e / R_p 0,2$ ) have been determine in tension tests involving tension specimen in accordance with DIN 50125- B6-30

These tests constitute the basis for the load bearing details given.

Material Description	Material no.	$R_e$ in N/mm <sup>2</sup>	$R_m$ in N/mm <sup>2</sup>
C45Pb	1.0504	560	640
X 10 CrNiS 18 9A	ISI 303	580	740

## Calculation example, load values

Example:

Index plungers with a bolt diameter of 6 mm made of Stainless Steel with a yield limit of  $R_e = 580 \text{ N/mm}^2$ , calculation against permanent deformation, the maximum permissible shear stress is calculated as:

$$F_{per} = \frac{(6 \text{ mm})^2 \times \pi}{4} \times 0,8 \times 580 \text{ N/mm}^2 = 13120 \text{ N}$$

d Bolt diameter	max. force F in N, acc. to material and strength value differs			
	C45Pb/1.05045		X 10 CrNiS 18 9/1.4305	
	at $R_e$	at $R_m$	at $R_e$	at $R_m$
3	3160	3610	3270	4180
4	5620	6430	5830	7430
5	790	10050	9110	11620
6	12660	14470	13120	16730
8	22510	25730	23320	29750
10	35180	40210	36440	46490
12	50660	57900	52470	66950
16	90070	102940	93290	119020

## Safety information

On principle, the design also needs an adequate safety coefficient to be taken into account. The usual safety coefficients under static load 1.2 to 1,5; pulsating 1.8 to 2.4 and alternating 3 to 4.

Disclaimer:

You should carry out your own test series to verify whether a certain product is suitable for your specific applications.