

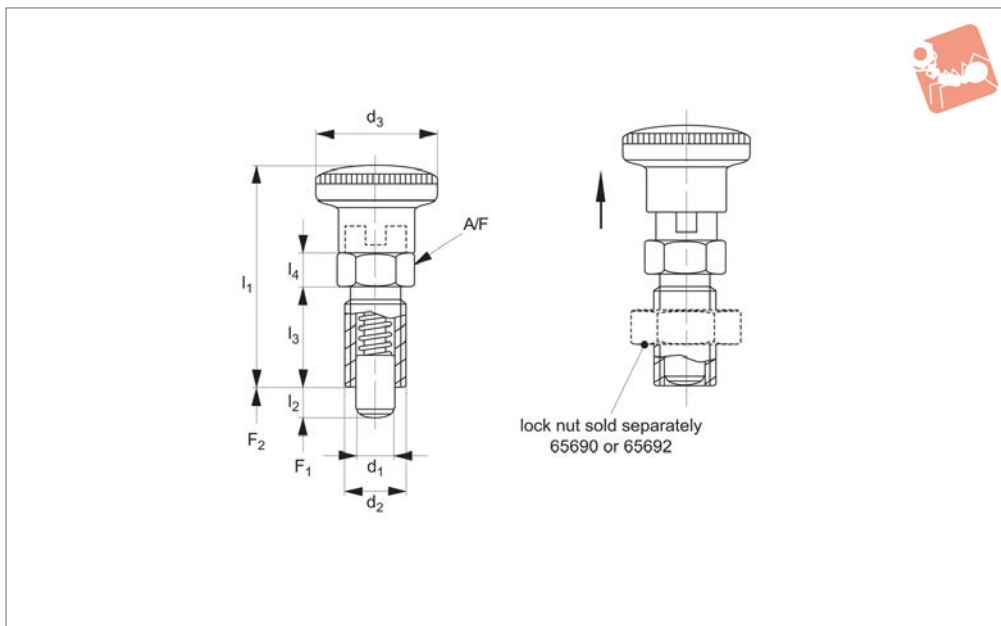

# Index Plungers - Compact compact -locking

# Index Plunger & Pins



## 32690

INDEX PLUNGER & PINS

### Material

#### Free cutting steel type-

Body: free cutting steel, blackened.

Pin: steel, hardened.

Grip: thermoplastic PA6, black.

#### Stainless steel type -

Body: stainless steel 1.4305 (AISI 303).

Pin: stainless steel 1.4305 (AISI 303), nickel plated.

Grip: thermoplastic PA6, black.

retracted/non-projecting position; pull back grip, turn 90° to engage ,locking' on a notched catch.

Thread recess on body allows full engagement of thread length. Hexagon collar improves leverage for secure installation. Benefits from a more compact design and hence shorter overall length.

Temperature resistance from -30° to +80°C.

adapt screw length.

**Lock nuts sold separately** See products 65690 & 65692

### Tips

Grip non-removable.

Spring loads \* = statistical average.

### Technical Notes

„Locking“ type- enable pin to be held in

Distance collars no. 32750 can be used to

Order No.	Type	Material	d <sub>1</sub> -0.02 -0.04	d <sub>2</sub>	d <sub>3</sub>	l <sub>1</sub>	l <sub>2</sub> min.	l <sub>3</sub>	l <sub>4</sub>	A/F	Spring load F <sub>1</sub> N ≈	Spring load F <sub>2</sub> N ≈	Weight g
32690.W0123	Locking	Steel	4	M 8x1,0	16	35	4	16	5	10	4.5	12.0	12.0
32690.W0124	Locking	Steel	4	M 8x1,0	16	35	6	16	5	10	4.0	12.5	12.0
32690.W0126	Locking	Steel	5	M10x1,0	19	40	5	18	6	12	5.0	15.0	20.0
32690.W0127	Locking	Steel	5	M10x1,0	19	40	8	18	6	12	5.0	18.0	20.0
32690.W0129	Locking	Steel	6	M12x1,5	23	48	6	22	6	14	6.5	19.0	31.0
32690.W0130	Locking	Steel	6	M12x1,5	23	48	9	22	6	14	6.0	25.0	33.0
32690.W0132	Locking	Steel	8	M16x1,5	28	58	8	26	8	17	8.5	26.0	65.0
32690.W0133	Locking	Steel	8	M16x1,5	28	58	12	26	8	17	8.5	28.0	68.0
32690.W0135	Locking	Steel	10	M16x1,5	28	58	12	26	8	17	9.5	38.0	69.0
32690.W0136	Locking	Steel	12	M20x1,5	33	67	15	33	10	22	11.5	40.0	125.0
32690.W0137	Locking	Steel	16	M24 x 2	33	78.5	20	38	12	27	13.0	54.0	220
32690.W0223	Locking	Stainless	4	M 8x1,0	16	35	4	16	5	10	4.5	12.0	12.0
32690.W0224	Locking	Stainless	4	M 8x1,0	16	35	6	16	5	10	4.0	12.5	12.0
32690.W0226	Locking	Stainless	5	M10x1,0	19	40	5	18	6	12	5.0	15.0	20.0
32690.W0227	Locking	Stainless	5	M10x1,0	19	40	8	18	6	12	5.0	18.0	20.0
32690.W0229	Locking	Stainless	6	M12x1,5	23	48	6	22	6	14	6.5	19.0	31.0
32690.W0230	Locking	Stainless	6	M12x1,5	23	48	9	22	6	14	6.0	25.0	33.0
32690.W0232	Locking	Stainless	8	M16x1,5	28	58	8	26	8	17	8.5	26.0	65.0
32690.W0233	Locking	Stainless	8	M16x1,5	28	58	12	26	8	17	8.5	28.0	68.0
32690.W0235	Locking	Stainless	10	M16x1,5	28	58	12	26	8	17	9.5	38.0	69.0
32690.W0236	Locking	Stainless	12	M20x1,5	33	67	15	33	10	22	11.5	40.0	125.0
32690.W0237	Locking	Stainless	16	M24 x 2	33	78.5	20	38	12	27	13.0	54.0	220





## A Wide Selection of Solutions

- Locating and positioning.
- Indexing.
- Securing.
- Positive locking.
- Rapid adjustment of all kinds of tables, platforms and fixtures.
- Machine and fixture design.
- OEM products.
- Sports equipment.
- Medical aides (wheelchairs etc.).
- Aerospace.
- Machine cabinets.

## Applications

## Materials

## Locking or Non Locking

## Handling and Actuation Methods

## Mounting Options

## Additional Technical Notes

## Spring Loads



Steel with plastic grip



Stainless with plastic grip



Stainless body and grip



Locking (park)



Non locking (spring back)



Push pull



Standard grip



Lever grip



T-handle



Pull ring

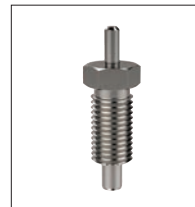

Threaded for bespoke handle



Fine threaded (standard)



Coarse thread



Flange mount



Thin wall mount



Weldable

- Unless otherwise stated, grips on index plungers are not removable.
- Many of the pins on index plungers are toleranced to either the pin or the hole. Please refer to the specific product table.
- Index plungers are not recommended for shear load applications.

	Pin Tol.	Hole Tol.
①	$h_9$	+0,03 +0,08
②	-0,02 -0,04	$H_7$

**s** Stroke, or movement of plunger's pin.

**f<sub>1</sub>** The force required in Newtons (N) to overcome the static strength of the spring and achieve initial movement of the plunger's pin.

**f<sub>2</sub>** The force required in Newtons (N) to fully compress the spring until the pin is fully depressed against the plunger's body.

