

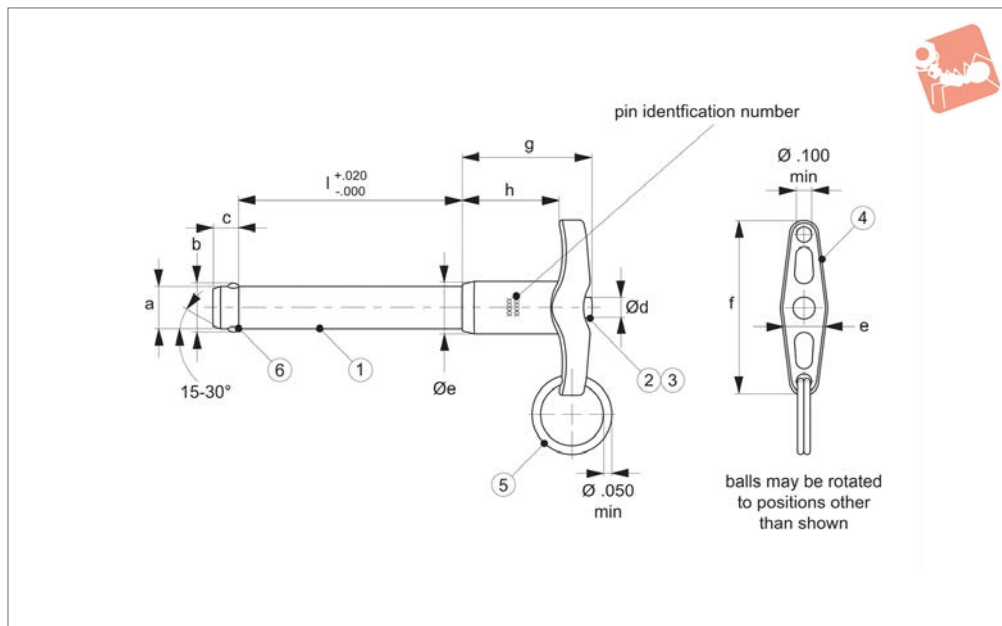

Aviation Pip-Pin - Standard T-Handle

single acting - quick release pins - according to

Ball Lock Pins & Quick Release



33610

BALL LOCK PINS & QUICK RELEASE PINS

Material

Shank (part 1) & spindle (part 2):

CRES 17-4PH (AMS 5643), heat treated per MIL-H-6875, condition H900, min. 40 HRC, passivated per AMS2700.

Spring (part 3, not shown):

CRES 302 (ASTM-A-313), heat treated per MIL-H-6875, passivated per AMS2700.

Handle (part 4):

A380 (QQ-A-591), anodized (black) per MIL-A-8625.

Attaching ring (part 5):

CRES 302 (ASTM-A-313), passivated per AMS2700.

Ball (locking element, part 6):

CRES CL440C (AMS5630), heat treated per MIL-H-6875, passivated per AMS2700.

Technical Notes

Wixroyd Aviation Pip-pins manufactured to Aviation Norm NASM 17985 (former norm: MS 17985) and tested to NAS 1332.

Manufacture certified & assessed to EN9100D by EASE (European Aerospace Supplier Evaluation).

Temp. range -22°F to 302°F

Pressing = unlocking.

Releasing = locking.

Pip-pins are used for frequently repeated operations such as quick fastening, locking, adjusting, changing and securing. All dimensions shown are imperial.

Tips

We can manufacture specials (both metric & imperial) to your drawing, and are certified to produce to NASM standards.

Wixroyd Aviation Pip-Pins can be produced within the following dimensions:

+ diameter: from 3/16" to 1"

+ grip length: from 0.3" to 9.9"

Quick production time on small batches.

Order No.	Dia. \varnothing inch nom.	Grip l inch	b_1	c_1	$\varnothing d$ max.	$\varnothing e$ max.	Weight g
33610.A003	3/16	0.3	,220	,260	,310	0.500	24
33610.A005	3/16	0.5	,220	,260	,310	0.500	24
33610.A008	3/16	0.8	,220	,260	,310	0.500	25
33610.A012	3/16	1.2	,220	,260	,310	0.500	26
33610.A013	3/16	1.3	,220	,260	,310	0.500	27
33610.A014	3/16	1.4	,220	,260	,310	0.500	27
33610.A026	3/16	2.6	,220	,260	,310	0.500	33
33610.B005	1/4	0.5	,289	,290	,310	0.500	26
33610.B009	1/4	0.9	,289	,290	,310	0.500	27
33610.B011	1/4	1.1	,289	,290	,310	0.500	28
33610.B012	1/4	1.2	,289	,290	,310	0.500	30
33610.B013	1/4	1.3	,289	,290	,310	0.500	30
33610.B015	1/4	1.5	,289	,290	,310	0.500	32
33610.B016	1/4	1.6	,289	,290	,310	0.500	33
33610.B021	1/4	2.1	,289	,290	,310	0.500	36
33610.B026	1/4	2.6	,289	,290	,310	0.500	40
33610.B028	1/4	2.8	,289	,290	,310	0.500	41
33610.B040	1/4	4.0	,289	,290	,310	0.500	49
33610.C003	5/16	0.3	,375	,330	,310	0.500	27
33610.C006	5/16	0.6	,375	,330	,310	0.500	30



BALL LOCK PINS & QUICK RELEASE PINS

Order No.	Dia. Ø inch nom.	Grip l inch	b ₁	c ₁	Ø d max.	Ø e max.	Weight g
33610.C010	5/16	1.0	,375	,330	,310	0.500	34
33610.C013	5/16	1.3	,375	,330	,310	0.500	36
33610.C015	5/16	1.5	,375	,330	,310	0.500	39
33610.C016	5/16	1.6	,375	,330	,310	0.500	39
33610.C018	5/16	1.8	,375	,330	,310	0.500	41
33610.C020	5/16	2.0	,375	,330	,310	0.500	43
33610.C023	5/16	2.3	,375	,330	,310	0.500	45
33610.C029	5/16	2.9	,375	,330	,310	0.500	52
33610.C030	5/16	3.0	,375	,330	,310	0.500	53
33610.C033	5/16	3.3	,375	,330	,310	0.500	56
33610.C040	5/16	4.0	,375	,330	,310	0.500	62
33610.C050	5/16	5.0	,375	,330	,310	0.500	75
33610.C064	5/16	6.4	,375	,330	,310	0.500	89
33610.C070	5/16	7.0	,375	,330	,310	0.500	93
33610.D005	3/8	0.5	,440	,365	,390	0.625	43
33610.D010	3/8	1.0	,440	,365	,390	0.625	48
33610.D012	3/8	1.2	,440	,365	,390	0.625	55
33610.D015	3/8	1.5	,440	,365	,390	0.625	57
33610.D016	3/8	1.6	,440	,365	,390	0.625	58
33610.D020	3/8	2.0	,440	,365	,390	0.625	60
33610.D024	3/8	2.4	,440	,365	,390	0.625	69
33610.D025	3/8	2.5	,440	,365	,390	0.625	72
33610.D026	3/8	2.6	,440	,365	,390	0.625	72
33610.D028	3/8	2.8	,440	,365	,390	0.625	72
33610.D031	3/8	3.1	,440	,365	,390	0.625	80
33610.D032	3/8	3.2	,440	,365	,390	0.625	80
33610.D035	3/8	3.5	,440	,365	,390	0.625	85
33610.D040	3/8	4.0	,440	,365	,390	0.625	91
33610.D045	3/8	4.5	,440	,365	,390	0.625	100
33610.E012	7/16	1.2	,509	,380	,390	0.625	60
33610.E018	7/16	1.8	,509	,380	,390	0.625	69
33610.E023	7/16	2.3	,509	,380	,390	0.625	82
33610.E024	7/16	2.4	,509	,380	,390	0.625	80
33610.E026	7/16	2.6	,509	,380	,390	0.625	90
33610.E029	7/16	2.9	,509	,380	,390	0.625	93
33610.E040	7/16	4.0	,509	,380	,390	0.625	113
33610.E042	7/16	4.2	,509	,380	,390	0.625	117
33610.E055	7/16	5.5	,509	,380	,390	0.625	145
33610.E072	1/2	7.2	,594	,460	,390	0.625	176
33610.F010	1/2	1.0	,594	,460	,565	0.800	82
33610.F012	1/2	1.2	,594	,460	,565	0.800	87
33610.F014	1/2	1.4	,594	,460	,565	0.800	94
33610.F015	1/2	1.5	,594	,460	,565	0.800	94
33610.F019	1/2	1.9	,594	,460	,565	0.800	106
33610.F020	1/2	2.0	,594	,460	,565	0.800	108
33610.F024	1/2	2.4	,594	,460	,565	0.800	117
33610.F029	1/2	2.9	,594	,460	,565	0.800	130
33610.F031	1/2	3.1	,594	,460	,565	0.800	135
33610.F036	1/2	3.6	,594	,460	,565	0.800	147
33610.F037	1/2	3.7	,594	,460	,565	0.800	146
33610.F040	1/2	4.0	,594	,460	,565	0.800	156
33610.F047	1/2	4.7	,594	,460	,565	0.800	177
33610.F048	1/2	4.8	,594	,460	,565	0.800	179
33610.F064	1/2	6.4	,594	,460	,565	0.800	218
33610.G017	9/16	1.7	,666	,510	,565	0.800	120
33610.G032	9/16	3.2	,666	,510	,565	0.800	160
33610.G036	9/16	3.6	,666	,510	,565	0.800	176
33610.G040	9/16	4.0	,666	,510	,565	0.800	190
33610.G061	9/16	6.1	,666	,510	,565	0.800	252

Order No.	Ø f max.	g ₁	h ₁	Shearing resistance, double lb min.	Location hole dia. max.	MS Part No.
33610.A003	1.815	1.27	0.800	5.150	0.1940	MS17985C303
33610.A005	1.815	1.27	0.800	5.150	0.1940	MS17985C305
33610.A008	1.815	1.27	0.800	5.150	0.1940	MS17985C308
33610.A012	1.815	1.27	0.800	5.150	0.1940	MS17985C312



Aviation Pip-Pin - Standard T-Handle

single acting - quick release pins - according to

Ball Lock Pins & Quick Release

Order No.	Ø f max.	g ₁	h ₁	Shearing resistance, double lb min.	Location hole dia. max.	MS Part No.
33610.A013	1.815	1.27	0.800	5.150	0.1940	MS17985C313
33610.A014	1.815	1.27	0.800	5.150	0.1940	MS17985C314
33610.A026	1.815	1.27	0.800	5.150	0.1940	MS17985C326
33610.B005	1.815	1.27	0.800	9.200	0.2540	MS17985C405
33610.B009	1.815	1.27	0.800	9.200	0.2540	MS17985C409
33610.B011	1.815	1.27	0.800	9.200	0.2540	MS17985C411
33610.B012	1.815	1.27	0.800	9.200	0.2540	MS17985C412
33610.B013	1.815	1.27	0.800	9.200	0.2540	MS17985C413
33610.B015	1.815	1.27	0.800	9.200	0.2540	MS17985C415
33610.B016	1.815	1.27	0.800	9.200	0.2540	MS17985C416
33610.B021	1.815	1.27	0.800	9.200	0.2540	MS17985C421
33610.B026	1.815	1.27	0.800	9.200	0.2540	MS17985C426
33610.B028	1.815	1.27	0.800	9.200	0.2540	MS17985C428
33610.B040	1.815	1.27	0.800	9.200	0.2540	MS17985C440
33610.C003	1.815	1.27	0.800	14.400	0.3165	MS17985C503
33610.C006	1.815	1.27	0.800	14.400	0.3165	MS17985C506
33610.C010	1.815	1.27	0.800	14.400	0.3165	MS17985C510
33610.C013	1.815	1.27	0.800	14.400	0.3165	MS17985C513
33610.C015	1.815	1.27	0.800	14.400	0.3165	MS17985C515
33610.C016	1.815	1.27	0.800	14.400	0.3165	MS17985C516
33610.C018	1.815	1.27	0.800	14.400	0.3165	MS17985C518
33610.C020	1.815	1.27	0.800	14.400	0.3165	MS17985C520
33610.C023	1.815	1.27	0.800	14.400	0.3165	MS17985C523
33610.C029	1.815	1.27	0.800	14.400	0.3165	MS17985C529
33610.C030	1.815	1.27	0.800	14.400	0.3165	MS17985C530
33610.C033	1.815	1.27	0.800	14.400	0.3165	MS17985C533
33610.C040	1.815	1.27	0.800	14.400	0.3165	MS17985C540
33610.C050	1.815	1.27	0.800	14.400	0.3165	MS17985C550
33610.C064	1.815	1.27	0.800	14.400	0.3165	MS17985C564
33610.C070	1.815	1.27	0.800	14.400	0.3165	MS17985C570
33610.D005	2.065	1.45	0.850	20.700	0.3790	MS17985C605
33610.D010	2.065	1.45	0.850	20.700	0.3790	MS17985C610
33610.D012	2.065	1.45	0.850	20.700	0.3790	MS17985C612
33610.D015	2.065	1.45	0.850	20.700	0.3790	MS17985C615
33610.D016	2.065	1.45	0.850	20.700	0.3790	MS17985C616
33610.D020	2.065	1.45	0.850	20.700	0.3790	MS17985C620
33610.D024	2.065	1.45	0.850	20.700	0.3790	MS17985C624
33610.D025	2.065	1.45	0.850	20.700	0.3790	MS17985C625
33610.D026	2.065	1.45	0.850	20.700	0.3790	MS17985C626
33610.D028	2.065	1.45	0.850	20.700	0.3790	MS17985C628
33610.D031	2.065	1.45	0.850	20.700	0.3790	MS17985C631
33610.D032	2.065	1.45	0.850	20.700	0.3790	MS17985C632
33610.D035	2.065	1.45	0.850	20.700	0.3790	MS17985C635
33610.D040	2.065	1.45	0.850	20.700	0.3790	MS17985C640
33610.D045	2.065	1.45	0.850	20.700	0.3790	MS17985C645
33610.E012	2.065	1.47	0.850	28.500	0.4425	MS17985C712
33610.E018	2.065	1.47	0.850	28.500	0.4425	MS17985C718
33610.E023	2.065	1.47	0.850	28.500	0.4425	MS17985C723
33610.E024	2.065	1.47	0.850	28.500	0.4425	MS17985C724
33610.E026	2.065	1.47	0.850	28.500	0.4425	MS17985C726
33610.E029	2.065	1.47	0.850	28.500	0.4425	MS17985C729
33610.E040	2.065	1.47	0.850	28.500	0.4425	MS17985C740
33610.E042	2.065	1.47	0.850	28.500	0.4425	MS17985C742
33610.E055	2.065	1.47	0.850	28.500	0.4425	MS17985C755
33610.E072	2.345	1.60	0.850	36.900	0.5050	MS17985C772
33610.F010	2.345	1.60	0.885	36.900	0.5050	MS17985C810
33610.F012	2.345	1.60	0.885	36.900	0.5050	MS17985C812
33610.F014	2.345	1.60	0.885	36.900	0.5050	MS17985C814
33610.F015	2.345	1.60	0.885	36.900	0.5050	MS17985C815
33610.F019	2.345	1.60	0.885	36.900	0.5050	MS17985C819
33610.F020	2.345	1.60	0.885	36.900	0.5050	MS17985C820
33610.F024	2.345	1.60	0.885	36.900	0.5050	MS17985C824
33610.F029	2.345	1.60	0.885	36.900	0.5050	MS17985C829
33610.F031	2.345	1.60	0.885	36.900	0.5050	MS17985C831
33610.F036	2.345	1.60	0.885	36.900	0.5050	MS17985C836
33610.F037	2.345	1.60	0.885	36.900	0.5050	MS17985C837
33610.F040	2.345	1.60	0.885	36.900	0.5050	MS17985C840

BALL LOCK PINS & QUICK RELEASE PINS

Ball Lock Pins & Quick Release



Aviation Pip-Pin - Standard T-Handle single acting - quick release pins - according to



Order No.	Ø f max.	g ₁	h ₁	Shearing resistance, double lb min.	Location hole dia. max.	MS Part No.
33610.F047	2.345	1.60	0.885	36.900	0.5050	MS17985C847
33610.F048	2.345	1.60	0.885	36.900	0.5050	MS17985C848
33610.F064	2.345	1.60	0.885	36.900	0.5050	MS17985C864
33610.G017	2.345	1.60	0.885	46.700	0.5675	MS17985C917
33610.G032	2.345	1.60	0.885	46.700	0.5675	MS17985C932
33610.G036	2.345	1.60	0.885	46.700	0.5675	MS17985C936
33610.G040	2.345	1.60	0.885	46.700	0.5675	MS17985C940
33610.G061	2.345	1.60	0.885	46.700	0.5675	MS17985C961

BALL LOCK PINS & QUICK RELEASE PINS



Wixroyd Flight Pin Range - Certified to Aviation Standards

With many years experience producing an extensive range of standard Pip-pins (also know as quick release pins or ball lock pins) we are now able to offer of Aviation Standard approved Pip-pins, manufactured according to NASM norms (formerly MS norms) and tested to NAS 1332 standards.



33600 - Single acting Pip-pin, standard B handle

33610 - Single acting Pip-pin, standard TA handle

33620 - Single acting Pip-pin, standard LA handle

33630 - Single acting Pip-pin, standard R handle

Expanding Range

- Interior panel attachment
- Baby bassinet pin
- Curtain track attachment

- Curtain track support pins
- TV monitor attachment
- Folding table assembly (e.g. First Class Cabins)

Wide Range of Aviation Applications

The Wixroyd Aviation Pip-pin range is produced according to NASM norms, and tested to NAS standards. Our manufacturing processes have been assessed and certified by EASE (European Aerospace Supplier Evaluation) to EN9100D.

All our Aviation Pip-pins are individually marked to enable identification of their production lot number.

Aviation Approved

Yes! The product sizes shown on the following pages, with a cross reference to the NASM part code for ease of identification, are all available from stock for delivery within 5 days.

In-Stock and Available?

We have extensive knowledge and experience in designing, producing and assembling bespoke design pip-pins and ball lock pins in both imperial and metric sizes. We produce under a fully certified manufacturing process, both to our own high standard or to meet Aviation standards.

Please contact our technical team to discuss your requirements (tel. 0845 26 66 577) or email a drawing to info@wixroyd.com

Special Designs

Free Literature | CAD download | Discover | Login | Basket | 0333 207 4497

Products > Wixroyd Design Elements

33600 Aviation Pip-Pin, Standard B Handle
single acting, quick release pins - according to NASM 17984, material: Steel.

pin identification number

grip length

all dimensions imperial

balls may be rotated to positions other than shown

Download product datasheet | Download FREE CAD

Alternative products you may wish to consider

For our full range visit:
wixroyd.com



Wixroyd Flight Pin Range - Certified to Aviation Standards

Your normal experience may be that imperial Aviation Standard Pip-pins are hard to obtain; price prohibitive, and delivery times far too long. The range of Wixroyd Aviation Pip-pins, in a variety of imperial dimensions, has been designed to solve these problems - we hold a wide, and ever increasing range of sizes ex-stock for immediate delivery - no more 6-8 week lead time!

With many years experience producing an extensive range of standard Pip-pins (also know as quick release pins or ball lock pins) we are now able to offer of Aviation Standard approved Pip-pins, manufactured according to NASM norms (formerly MS norms) and tested to NAS 1332 standards.

Wide Range of Aviation Applications

- Interior panel attachment
- Baby bassinet pin
- Curtain track attachment
- Curtain track support pins
- TV monitor attachment
- Folding table assembly (e.g. First Class Cabins)

In-stock and Available?

Yes! The product sizes shown on the following pages, with a cross reference to the NASM part code for ease of identification, are all available from stock for delivery within 5 days.

Materials

Our Aviation Pip-pins are manufactured to NASM norms, and we follow the material specification of these norms, which means you can feel safe in purchasing a part which is to specification - both in materials and strength.

Aviation Approved



The new Wixroyd Aviation Pip-pin range is produced according to NASM norms, and tested to NAS standards. Our manufacturing processes have been assessed and certified by EASE (European Aerospace Supplier Evaluation) to EN9100D.

Identifying Production Batches

All our Aviation Pip-pins are individually marked to enable identification of their production lot number. Marking allows identification of:

- NASM Standard Number
- Material Grade
- Pin/shank diameter
- Grip length
- Company identification
- Production lot number.

Special Designs

We have extensive knowledge and experience in designing, producing and assembling bespoke design pip-pins and ball lock pins in both imperial and metric sizes. We produce under a fully certified manufacturing process, both to our own high standard or to meet Aviation standards.

We can customise to meet your needs:

- Changes in grip/handle type
- Material variations
- Changes of functional dimensions; pin diameter, pin grip length

Please contact our technical team to discuss your requirements (tel. 0845 26 66 577) or email a drawing to info@wixroyd.com

Expanding Range



Single acting Pip-pin, standard B handle



Single acting Pip-pin, standard TA handle



Single acting Pip-pin, standard LA handle



Single acting Pip-pin, standard R handle