



Self-Aligning Pads

hard metal ball - ribbed - stainless steel



Self-Aligning Pads

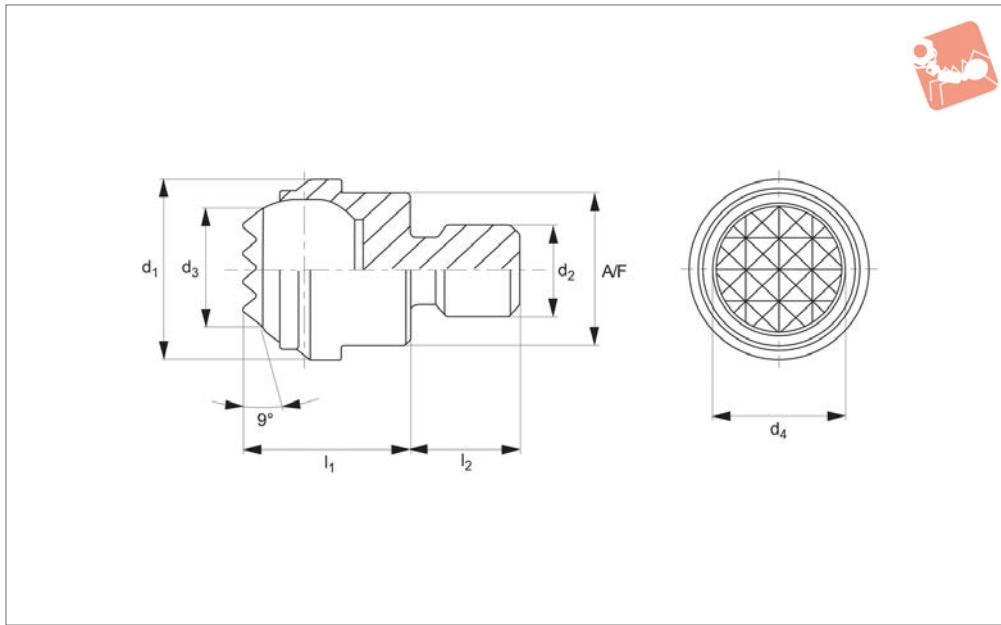

34081

SELF-ALIGNING PADS

Material

Body: stainless steel (AISI 431, 1.4057), heat treated.
Ball: hard metal, nickel plated.

Technical Notes

Ideal as stop, support or thrust pad especially where cast components are being machined. Insert is brazed in position.

Tips

Ball secured against turning.

Order No.	d ₁	d ₂	d ₃	d ₄	l ₁ ±0.2	l ₂ -0.5	A/F	Static load kN max.	Tightening torque Nm max.	Weight g
34081.W0390	13	M 6	8.3	10	13	8	11	10	10	14.0
34081.W0392	13	M 8	8.3	10	13	8	11	10	25	16.0
34081.W0394	20	M 8	12.8	16	18	10	17	25	25	49.0
34081.W0396	20	M10	12.8	16	18	10	17	25	46	51.0
34081.W0398	20	M12	12.8	16	18	12	17	25	82	54.0
34081.W0399	30	M16	20.0	25	27	16	27	90	206	190.0
34081.W0400	50	M20	34.5	40	35	20	41	165	407	639.0
34081.W0401	50	M24	34.5	40	35	24	41	165	407	673.0



Clamping, supporting and aligning non-parallel and uneven surfaces is greatly simplified with the use of Wixroyd self-aligning pads and thrust screws. Available with ridged faces for improved holding of cast components, or plastic faces for holding more delicate parts.

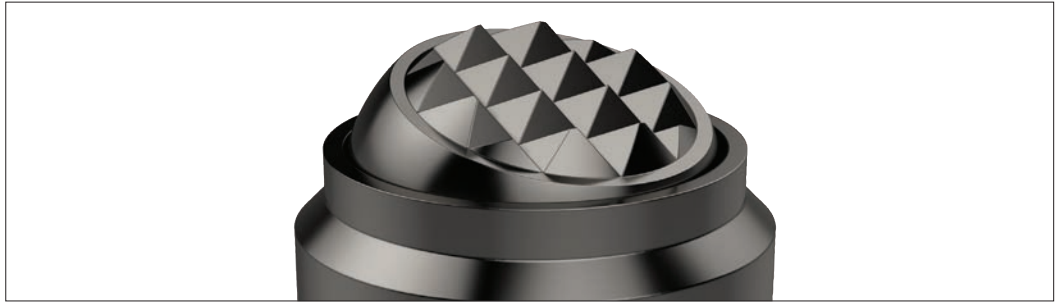

Self-aligning Thrust Screws

34000 to 34060 - Self-aligning thrust screws in sizes M6 to M24, ideal for clamping or supporting non-parallel surfaces.

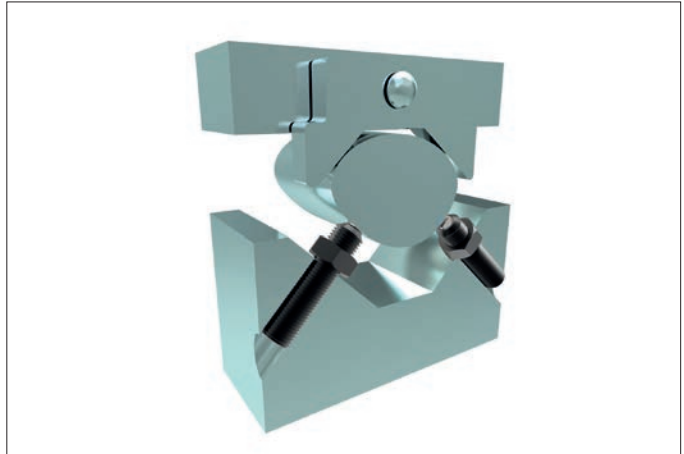

Self-aligning Pads

34080 to 34121 - Self-aligning pads, both male and female mounting, ideal for accommodating variations between parts in fixtures.

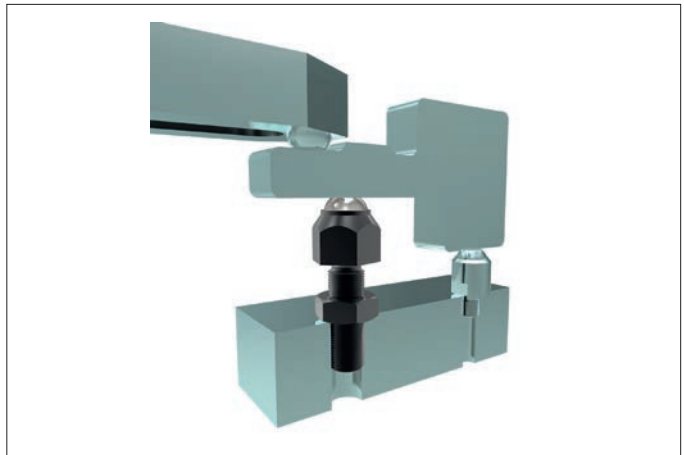
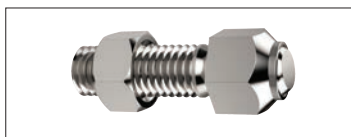
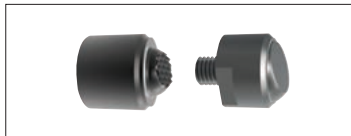

Thrust Screws

34140 to 34160 - Thrust screws, with either brass or thermoplastic pads, are suitable for gentle clamping and positioning more delicate parts.

