

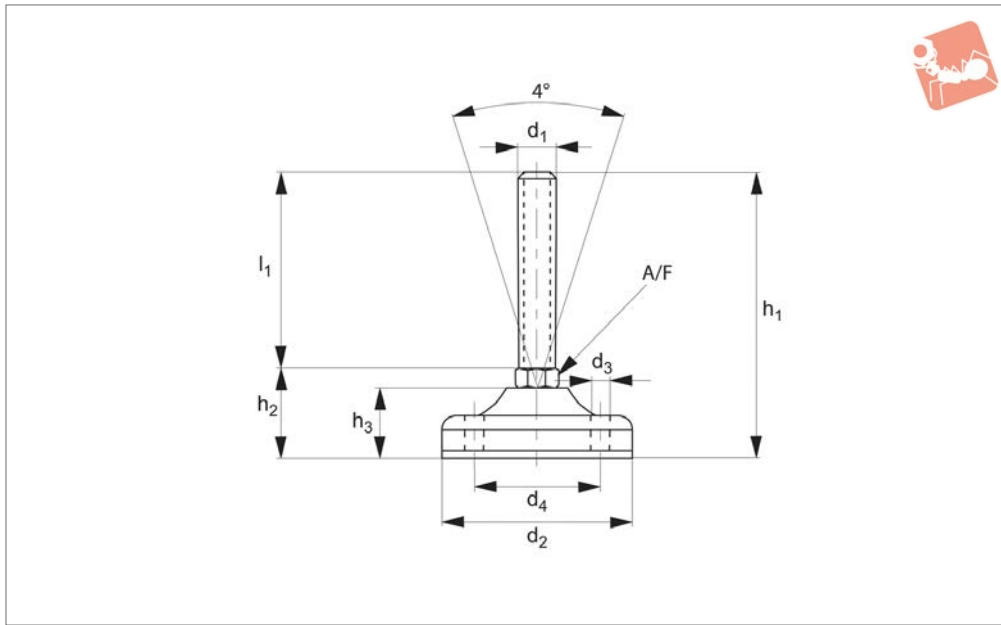

Machine Mount

plastic pad, bolt black polyamide bolt down option

Levelling Feet



34754

LEVELLING FEET

Material

Pad: black polyamide.
Bolt: stainless steel AISI 303.

Pad insert: nitril rubber.

half the screw height.

Technical Notes

Load values refer to static loads, located at

Order No.	d ₁	l ₁	d ₂	d ₃	d ₄	h ₁	h ₂	h ₃	A/F	Load kN max.
34754.W1000	M10	50	83	8.5	56	89	39	31	14	15
34754.W1001	M10	75	83	8.5	56	114	39	31	14	15
34754.W1002	M10	100	83	8.5	56	139	39	31	14	15
34754.W1003	M10	125	83	8.5	56	164	39	31	14	15
34754.W1200	M12	50	83	8.5	56	89	39	31	14	15
34754.W1201	M12	75	83	8.5	56	114	39	31	14	15
34754.W1202	M12	100	83	8.5	56	139	39	31	14	15
34754.W1203	M12	125	83	8.5	56	164	39	31	14	15
34754.W1400	M14	50	83	8.5	56	89	39	31	14	20
34754.W1401	M14	75	83	8.5	56	114	39	31	14	20
34754.W1402	M14	100	83	8.5	56	139	39	31	14	20
34754.W1403	M14	125	83	8.5	56	164	39	31	14	20
34754.W1404	M14	150	83	8.5	56	189	39	31	14	20
34754.W1405	M14	175	83	8.5	56	215	39	31	14	20
34754.W1600	M16	50	83	8.5	56	93	43	31	13	20
34754.W1601	M16	75	83	8.5	56	118	43	31	13	20
34754.W1602	M16	100	83	8.5	56	143	43	31	13	20
34754.W1603	M16	125	83	8.5	56	168	43	31	13	20
34754.W1604	M16	150	83	8.5	56	193	43	31	13	20
34754.W1605	M16	175	83	8.5	56	218	43	31	13	20
34754.W1606	M16	200	83	8.5	56	243	43	31	13	20
34754.W1607	M16	50	103	12.5	73	98	48	36	17	35
34754.W1608	M16	75	103	12.5	73	123	48	36	17	35
34754.W1609	M16	100	103	12.5	73	148	48	36	17	35
34754.W1610	M16	125	103	12.5	73	173	48	36	17	35
34754.W1611	M16	150	103	12.5	73	198	48	36	17	35
34754.W1612	M16	175	103	12.5	73	223	48	36	17	35
34754.W1613	M16	200	103	12.5	73	248	48	36	17	35
34754.W1614	M16	225	103	12.5	73	273	48	36	17	35
34754.W1615	M16	50	123	12.5	87	103	53	40	20	45
34754.W1616	M16	75	123	12.5	87	128	53	40	20	45
34754.W1617	M16	100	123	12.5	87	153	53	40	20	45
34754.W1618	M16	125	123	12.5	87	178	53	40	20	45
34754.W1619	M16	150	123	12.5	87	203	53	40	20	45



Order No.	d ₁	l ₁	d ₂	d ₃	d ₄	h ₁	h ₂	h ₃	A/F	Load kN max.
34754.W1620	M16	175	123	12.5	87	228	53	40	20	45
34754.W1621	M16	200	123	12.5	87	253	53	40	20	45
34754.W1622	M16	225	123	12.5	87	278	53	40	20	45
34754.W2000	M20	75	83	8.5	56	118	43	34	17	20
34754.W2001	M20	100	83	8.5	56	143	43	34	17	20
34754.W2002	M20	125	83	8.5	56	168	43	34	17	20
34754.W2003	M20	150	83	8.5	56	193	43	34	17	20
34754.W2004	M20	175	83	8.5	56	218	43	34	17	20
34754.W2005	M20	200	83	8.5	56	243	43	34	17	20
34754.W2006	M20	225	83	8.5	56	268	43	34	17	20
34754.W2007	M20	75	103	12.5	73	123	48	36	17	35
34754.W2008	M20	100	103	12.5	73	148	48	36	17	35
34754.W2009	M20	125	103	12.5	73	173	48	36	17	35
34754.W2010	M20	150	103	12.5	73	198	48	36	17	35
34754.W2011	M20	175	103	12.5	73	223	48	36	17	35
34754.W2012	M20	200	103	12.5	73	248	48	36	17	35
34754.W2013	M20	225	103	12.5	73	273	48	36	17	35
34754.W2014	M20	75	123	12.5	87	128	53	40	20	45
34754.W2015	M20	100	123	12.5	87	153	53	40	20	45
34754.W2016	M20	125	123	12.5	87	178	53	40	20	45
34754.W2017	M20	150	123	12.5	87	203	53	40	20	45
34754.W2018	M20	175	123	12.5	87	228	53	40	20	45
34754.W2019	M20	200	123	12.5	87	253	53	40	20	45
34754.W2020	M20	225	123	12.5	87	278	53	40	20	45
34754.W2400	M24	75	103	12.5	73	125	50	36	20	35
34754.W2401	M24	100	103	12.5	73	150	50	36	20	35
34754.W2402	M24	125	103	12.5	73	175	50	36	20	35
34754.W2403	M24	150	103	12.5	73	200	50	36	20	35
34754.W2404	M24	175	103	12.5	73	225	50	36	20	35
34754.W2405	M24	200	103	12.5	73	250	50	36	20	35
34754.W2406	M24	225	103	12.5	73	275	50	36	20	35
34754.W2407	M24	75	123	12.5	87	128	53	40	20	45
34754.W2408	M24	100	123	12.5	87	153	53	40	20	45
34754.W2409	M24	125	123	12.5	87	178	53	40	20	45
34754.W2410	M24	150	123	12.5	87	203	53	40	20	45
34754.W2411	M24	175	123	12.5	87	228	53	40	20	45
34754.W2412	M24	200	123	12.5	87	253	53	40	20	45
34754.W2413	M24	225	123	12.5	87	278	53	40	20	45
34754.W2414	M24	250	123	12.5	87	303	53	40	20	45
34754.W3000	M30	100	123	12.5	87	153	53	40	26	45
34754.W3001	M30	125	123	12.5	87	178	53	40	26	45
34754.W3002	M30	150	123	12.5	87	203	53	40	26	45
34754.W3003	M30	175	123	12.5	87	228	53	40	26	45
34754.W3004	M30	200	123	12.5	87	253	53	40	26	45
34754.W3005	M30	225	123	12.5	87	278	53	40	26	45
34754.W3006	M30	250	123	12.5	87	303	53	40	26	45



All levelling feet can be produced with the following fixing types:

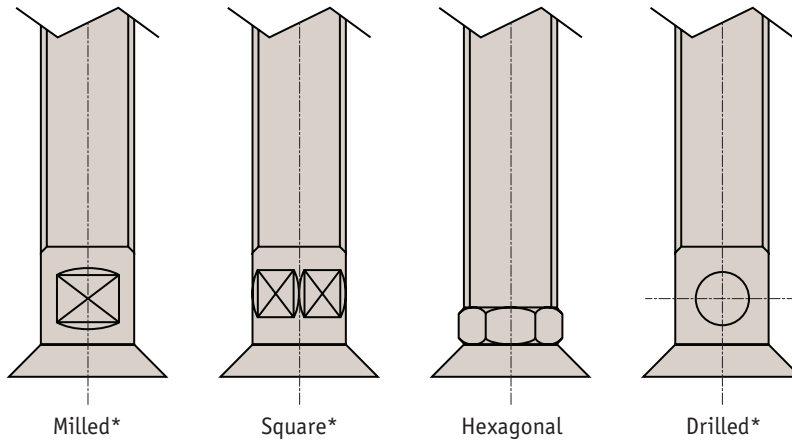
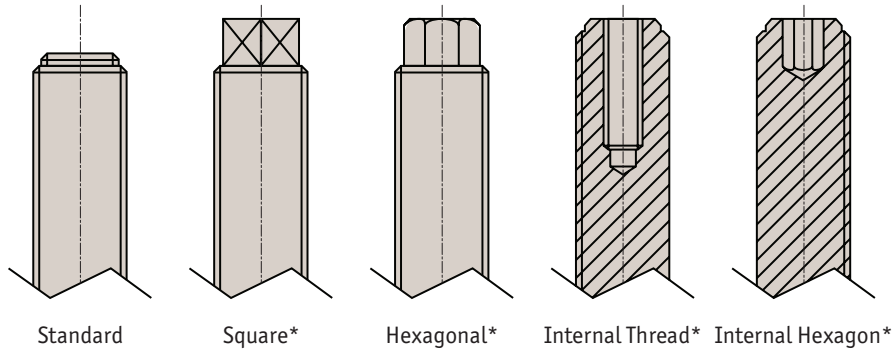

Thread versions

- Metric thread - coarse pitch (standard)
- Metric thread - fine pitch
- Thread gas 55°
- Imperial thread Unc
- Whitworth thread

* For non-standard threads a minimum order will apply.

Levelling Feet from Automation Components

LEVELLING FEET