

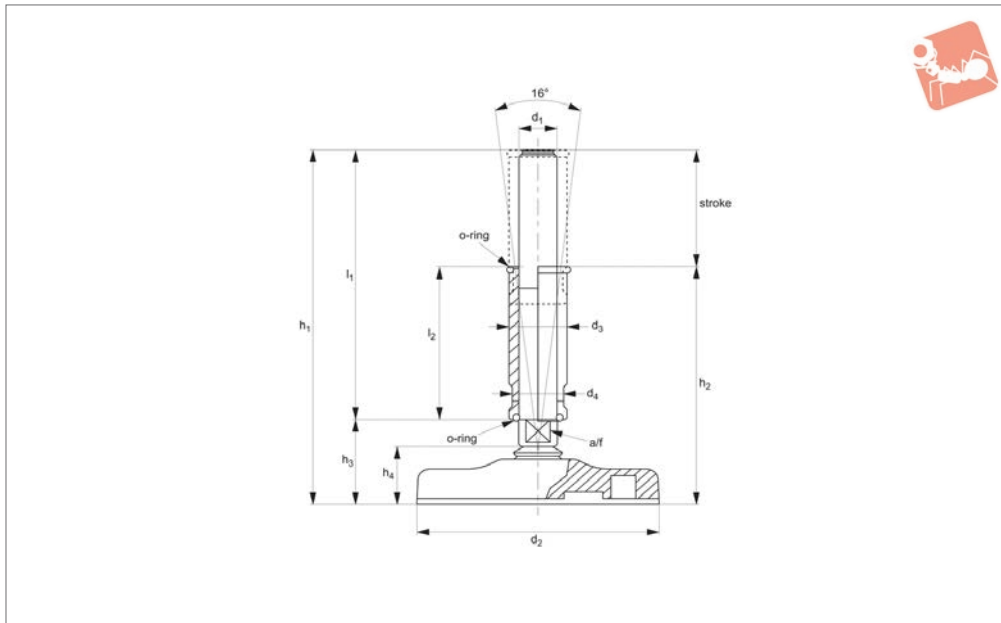

Hygienic Levelling Feet

stainless steel, with plastic base

Levelling Feet



34771

LEVELLING FEET

Material

Base: polyamide base.
Screw: stainless steel 304.

Technical Notes

Nut shroud is used to cover the exposed threaded section of the levelling foot, and hence prevents areas of contamination. In

addition the rubber seal between base and bolt adds to the ease of cleaning.

Load values shown are for static loads calculated at the half of the screw length. In the presence of vibrations or dynamic loads these values should be reduced.

Tips

Specifically designed for food & drink, pharmaceutical & clean room applications where hygiene is of prime importance and ingress of materials is to be minimised.

Order No.	Stroke	d ₁	d ₂	d ₃	d ₄	l ₁	l ₂	h ₁	h ₂	h ₃	A/F	Static load kN
34771.W2000	65mm	M20	103	30	26	150	85	193	128	43	17	20
34771.W2001	65mm	M20	123	30	26	150	85	195	130	45	20	30
34771.W2400	65mm	M24	103	35	30	150	85	194	129	44	17	20
34771.W2401	65mm	M24	123	35	30	150	85	196	131	46	20	30
34771.W3000	65mm	M30	123	42	36	150	85	197	132	47	26	30