

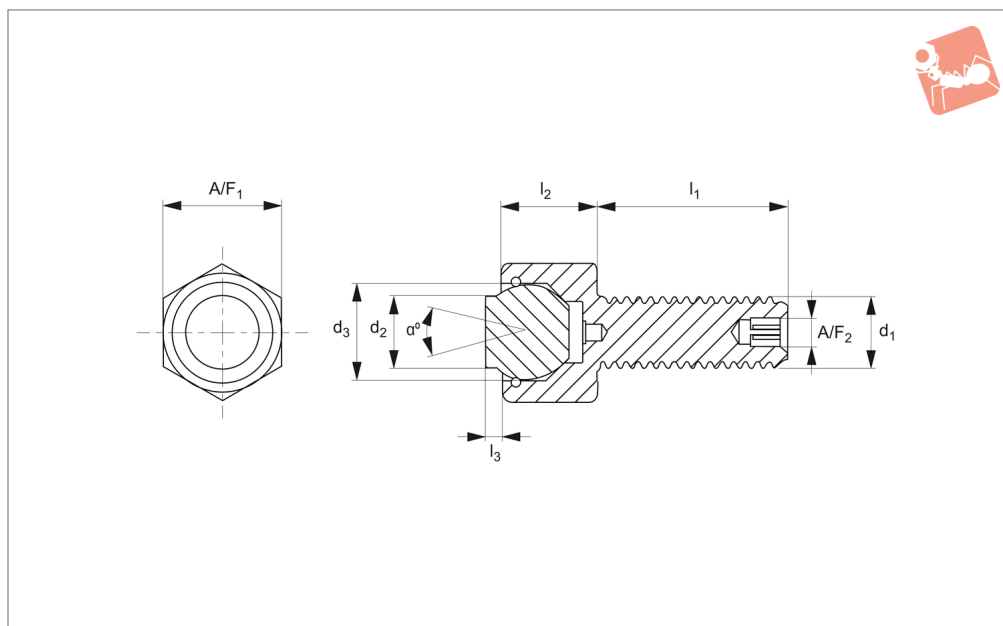

# Grippers - Self Aligning - Plastic

flat - threaded bolt

## Grippers & Rest Pads



### 35530.3

GRIPPERS & REST PADS

#### Material

Body: steel, hardened to HRC 43/46, black oxide finish.

Ball: thermoplastic, white.

Viton o-ring holds ball in place and

prevents ingress of other material.

#### Technical Notes

These adjustable self-aligning pads serve as stops, supports and thrust elements in

jigs and fixtures. They can also be fitted to existing workholding elements.

Use low-profile hexagon nut (DIN 439B) for adjustment and securing if required.

Order No.	d <sub>1</sub>	d <sub>2</sub>	d <sub>3</sub>	l <sub>1</sub>	l <sub>2</sub> ±0.05	l <sub>3</sub>	Swivel angle a	A/F <sub>1</sub>	A/F <sub>2</sub>
35530.W0201	M 6X1,0	6.0	7	12	8.0	1.5	28	10	-
35530.W0202	M 6X1,0	6.0	7	12	8.0	3.0	28	10	-
35530.W0203	M 6X1,0	6.0	7	25	8.0	1.5	28	10	-
35530.W0204	M 6X1,0	6.0	7	25	8.0	3.0	28	10	-
35530.W0205	M 6X1,0	6.0	7	40	8.0	1.5	28	10	-
35530.W0206	M 6X1,0	6.0	7	40	8.0	3.0	28	10	-
35530.W0207	M 8X1,25	8.5	10	12	11.5	1.5	24	13	-
35530.W0208	M 8X1,25	8.5	10	12	11.5	3.0	24	13	-
35530.W0209	M 8X1,25	8.5	10	25	11.5	1.5	24	13	-
35530.W0210	M 8X1,25	8.5	10	25	11.5	3.0	24	13	-
35530.W0211	M 8X1,25	8.5	10	40	11.5	1.5	24	13	-
35530.W0212	M 8X1,25	8.5	10	40	11.5	3.0	24	13	-
35530.W0213	M10X1,5	10.0	13	15	13.0	4.0	42	17	3
35530.W0214	M10X1,5	10.0	13	15	13.0	6.0	42	17	3
35530.W0215	M10X1,5	10.0	13	30	13.0	4.0	42	17	3
35530.W0216	M10X1,5	10.0	13	30	13.0	6.0	42	17	3
35530.W0217	M10X1,5	10.0	13	50	13.0	4.0	42	17	3
35530.W0218	M10X1,5	10.0	13	50	13.0	6.0	42	17	3
35530.W0219	M12X1,75	12.0	15	20	15.0	4.0	45	19	5
35530.W0220	M12X1,75	12.0	15	20	15.0	6.0	45	19	5
35530.W0221	M12X1,75	12.0	15	40	15.0	4.0	45	19	5
35530.W0222	M12X1,75	12.0	15	40	15.0	6.0	45	19	5
35530.W0223	M12X1,75	12.0	15	60	15.0	4.0	45	19	5
35530.W0224	M12X1,75	12.0	15	60	15.0	6.0	45	19	5
35530.W0225	M16X2,0	16.0	20	25	19.0	4.0	40	24	6
35530.W0227	M16X2,0	16.0	20	50	19.0	4.0	40	24	6
35530.W0229	M16X2,0	16.0	20	80	19.0	4.0	40	24	6

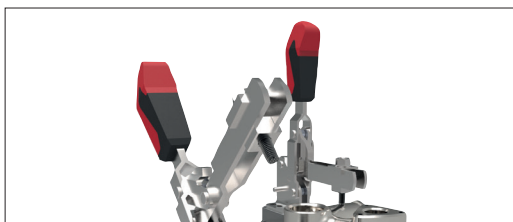

Grippers enhance workholding for multiple machining operations.

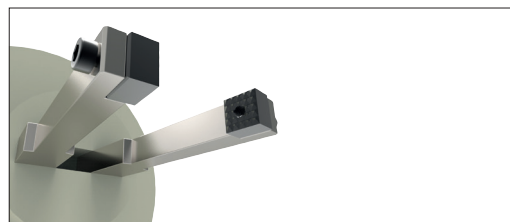

Grippers increase handling capability.

## Pads and Gripper Options

### Pads

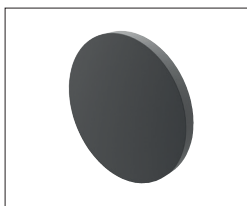

**Solid Carbide**  
High impact carbide pads, can be brazed or bonded into place.



**Carbide Tipped**  
Constructed with high impact carbide pad brazed to a heat treated alloy steel body. Mount via tapped hole or a flat on the outside diameter for set screw mounting.

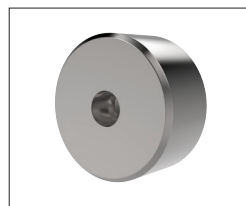

**Hardened Steel**  
Made from 8620 steel, carburized and hardened to Rc 58/60 1.2mm with black oxide finish. Mount via tapped or counter bored hole.

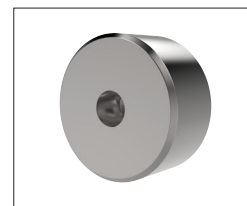

**Non-marking Thermoplast**  
Made from white thermoplast. Mount via tapped or counter bored hole.



**Stainless Steel**  
Pad from 17-4 stainless steel, hardened to Rc 43/46. Mount via tapped or counter bored hole.

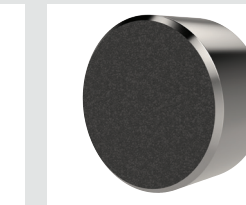

**Abrasive Diamond Surface**  
Abrasive surface permanently fused to a 17-4 stainless steel pad, hardened to Rc 43/46. The surface texture is comparable to a 100 grit abrasive. Mount via tapped or counter bored hole.

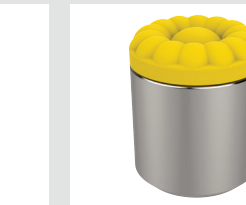

**Soft Urethane Surface**  
Urethane surface is permanently bonded to a 300 series stainless steel pad. The urethane provides excellent protection against damage on delicate work surfaces. Tapped hole mounting.

see our website for our full range:  
[wixroyd.com](http://wixroyd.com)

### Grippers

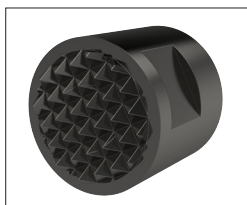

**High Speed Tool Steel**  
Manufactured from M-2 high speed tool steel, hardened to Rc 60/62 with black oxide finish. Mount via tapped hole, counter bored hole or a flat on the outside diameter for set screw mounting.

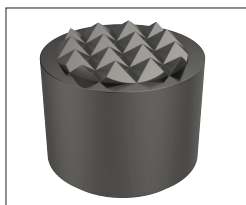

**Carbide Tipped**  
Constructed with high impact carbide pad brazed to a heat treated alloy steel body. Mounts via tapped hole or a flat on the outside diameter for set screw mounting.

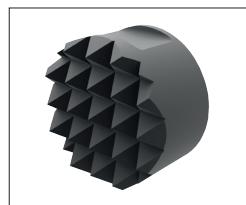

**Solid Carbide**  
Manufactured from high impact carbide in a solid gripper pad or as a solid gripper body with a threaded brazed-in steel insert. Mount via tapped hole or a flat on the outside diameter for set screw mounting.



### A Range of Specialist Gripping Pads to Suit Your Application



Unique urethane coat prevents marking of delicate components during machining or manipulation by robots. The urethane pad is permanently bonded to the stainless steel body of the gripping pad. With a bubbled texture, air is able to escape and hence avoid any suction action - enabling easy releasing of parts.

#### Urethane Coated

These are available in three different urethane durometers.

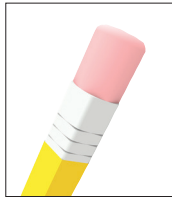

**35 durometer:**  
Pencil rubber top



**60 durometer:**  
Car tyre

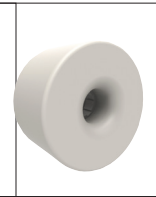

**80 durometer:**  
Skateboard wheel

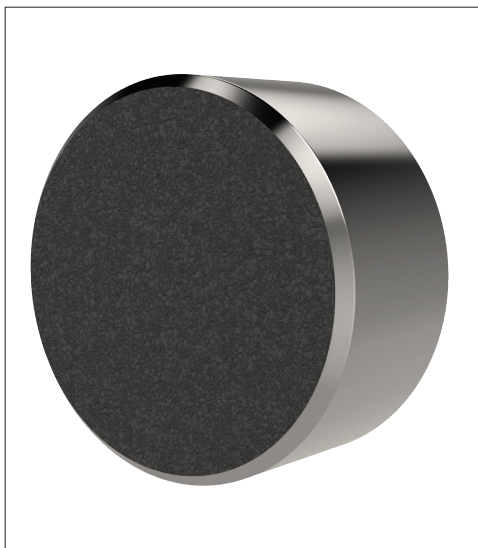

To improve handling of smooth or slippery components, with a minimum of clamping pressure, our abrasive diamond coated pads provide an excellent solution.

#### Abrasive Diamond Coated

Diamond powders are permanently fused to a 17-4 stainless pad, to provide an abrasive surface comparable to 100 grit value.

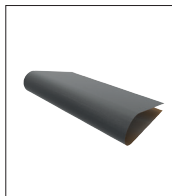

**Sandpaper of 100 grit texture**

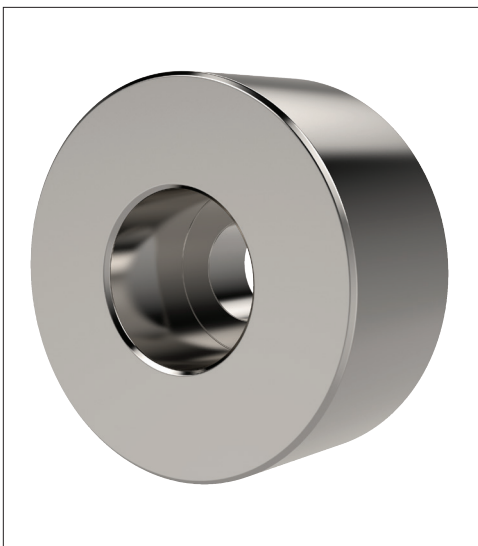

Pads of 17-4 Stainless, hardened to RC 43/46 provide solutions to applications where material selection is of greater importance; for example nuclear or food processing or pharmaceutical applications.

#### Stainless Pads