



Expander® Sealing Plugs

stainless steel body



Sealing Screws

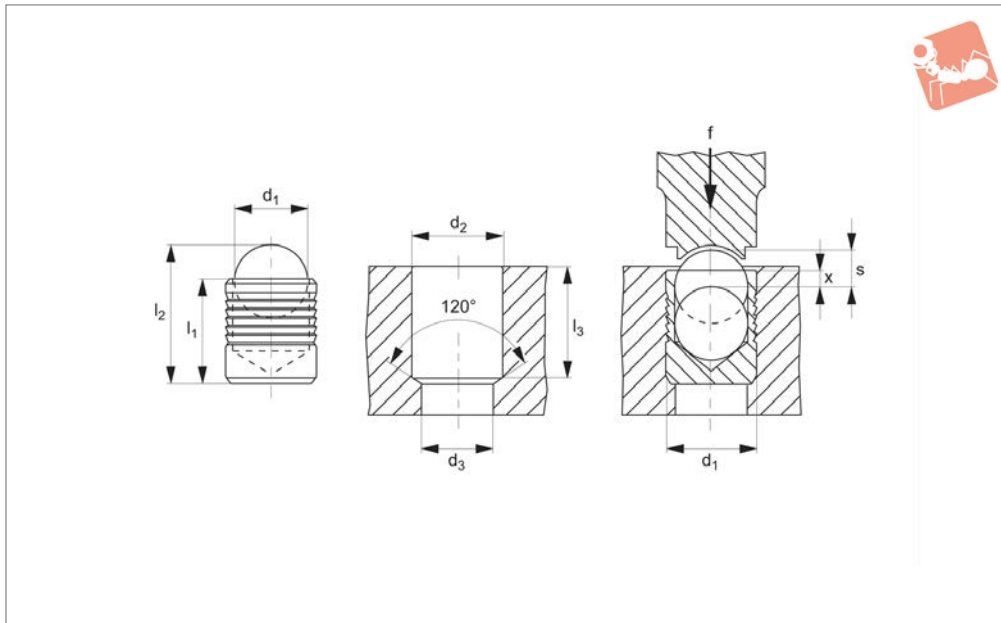

39100

SEALING SCREWS

Material

Body: stainless steel 1,4305 (AISI 303).
Ball: roller bearing steel, heat-treated, tempered.

quick and economic sealing of bore holes in fluid technology, e.g. hydraulic drilling holes in jig and fixtures. Setting dies are required for assembly.

nical pages.

Technical Notes

Expander sealing plugs are used for safe,

Tips

For assembly instructions please see tech-

Order No.	d ₁	l ₁	l ₂ ≈	d ₂ +0.1	d ₃ max.	l ₃ min.	x ±0.2	s	Weight g
39100.W0053	3	3.6	4.6	3	2.2	3.4	0.4	1.20	0.1
39100.W0054	4	4.0	5.2	4	3.3	3.8	0.2	1.50	0.3
39100.W0055	5	5.5	7.0	5	4.3	5.3	0.4	2.00	0.7
39100.W0056	6	6.5	8.6	6	5.3	6.3	0.4	2.50	1.3
39100.W0057	7	7.5	10.1	7	6.4	7.3	0.4	3.00	2.4
39100.W0058	8	8.5	11.7	8	7.4	8.3	0.3	3.50	3.2
39100.W0059	9	10.0	13.7	9	8.4	9.8	0.4	4.00	4.5
39100.W0060	10	11.0	15.2	10	9.4	10.8	0.4	4.50	6.1
39100.W0062	12	13.0	18.0	12	10.6	12.8	0.4	5.50	9.7
39100.W0064	14	15.0	20.8	14	12.7	14.5	0.4	6.35	15.0
39100.W0066	16	17.0	23.7	16	14.7	16.5	0.6	7.00	22.0
39100.W0068	18	19.0	26.3	18	16.7	18.5	0.6	8.00	31.0
39100.W0070	20	22.0	30.5	20	18.7	21.5	0.8	9.00	46.0
39100.W0072	22	25.0	34.2	22	20.7	24.5	0.8	10.00	58.0

