

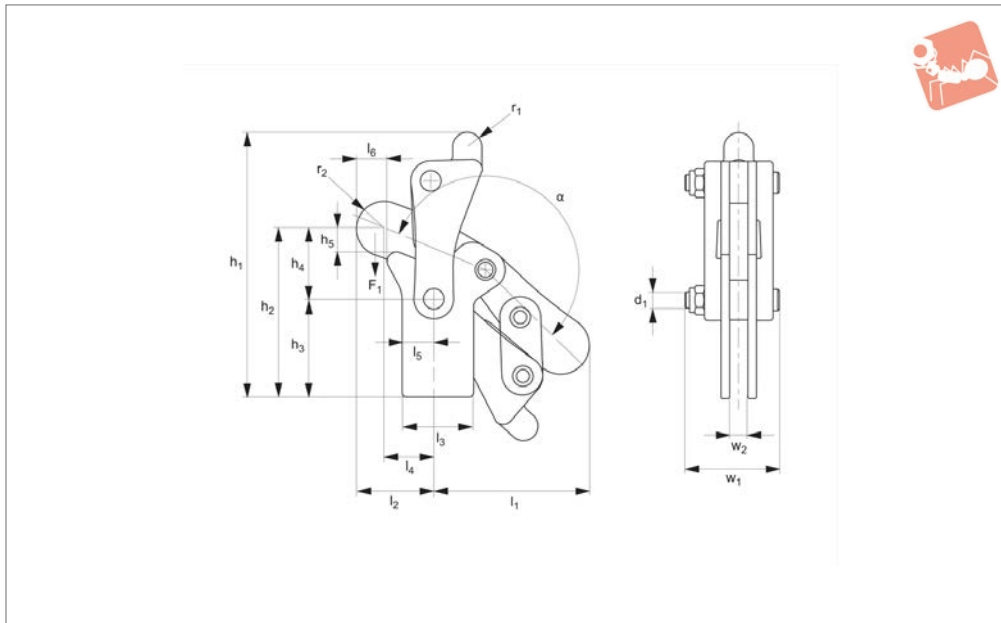

Modular Toggle Clamp

vertical foot - welding version

Heavy Duty Toggle Clamps



46060

HEAVY DUTY TOGGLE CLAMPS

Material

Body: steel, black oxide coated.
 Lever: cast steel, black oxide coated.
 Bushes: reamed and case hardened bearings.
 Pins: hardened, ground and permanently

lubricated.

Technical Notes

Clamp nuts on lever arm enable adjustment of friction in clamp movement.
 Temperature range -10°C to +80°C.

Tips

Supplement these base modular toggle clamps with your own clamping arms, handles etc. to meet the requirements of your specific application.

| Order No. | Size | F ₁ kN | h ₁ | h ₂ | h ₃ | h ₄ | h ₅ | l ₁ | l ₂ | Weight g |
|-------------|------|----------------------|----------------|----------------|----------------|----------------|----------------|----------------|----------------|-------------|
| 46060.W0002 | 2 | 2.5 | 90 | 52 | 34 | 18 | 5 | 58 | 32 | 245 |
| 46060.W0004 | 4 | 7.0 | 142 | 88 | 50 | 38 | 12 | 82 | 41 | 970 |
| 46060.W0006 | 6 | 11.0 | 182 | 114 | 64 | 50 | 16 | 106 | 55 | 1750 |
| 46060.W0008 | 8 | 22.5 | 218 | 140 | 76 | 64 | 19 | 135 | 72 | 3310 |
| 46060.W0010 | 10 | 34.0 | 266 | 173 | 90 | 83 | 25 | 155 | 77 | 5970 |

| Order No. | l ₃ | l ₄ | l ₅ | l ₆ | r ₁ | r ₂ | w ₁ | w ₂ | d ₁ | α |
|-------------|----------------|----------------|----------------|----------------|----------------|----------------|----------------|----------------|----------------|------|
| 46060.W0002 | 30 | 22 | 14 | 12 | 5 | 10.0 | 31 | 6 | M 6 | 190° |
| 46060.W0004 | 44 | 26 | 19 | 16 | 8 | 15.0 | 52 | 10 | M 8 | 190° |
| 46060.W0006 | 55 | 36 | 28 | 20 | 11 | 18.0 | 60 | 12 | M10 | 190° |
| 46060.W0008 | 66 | 50 | 37 | 27 | 14 | 22.5 | 76 | 16 | M12 | 190° |
| 46060.W0010 | 80 | 52 | 40 | 22 | 14 | 25.0 | 90 | 20 | M16 | 190° |