

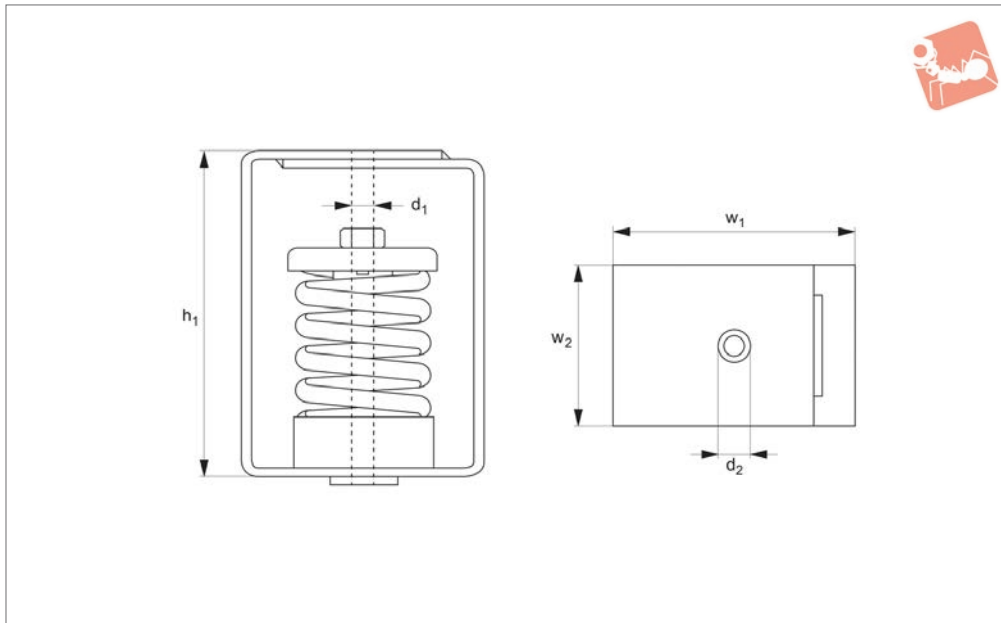

Acoustic Suspension Hanger spring spring

Anti-Vibration



61931

ANTI-VIBRATION

Material

Zinc plated steel (anti-corrosive treatment).

where objects are suspended from ceilings. The spring in the body provides good anti-vibration properties.

load to be carried per unit.

These hanger can be used for fans, distribution pipes, ducts and acoustic ceilings.

Technical Notes

These units are designed for installations

Tips

Select the damper corresponding to the

Order No.	d_1	w_1	h_1	d_2	w_2	h_1	Load kgf max.
61931.W0025	M 8	75	120	12	50	25	25
61931.W0050	M 8	75	120	12	50	50	50
61931.W0075	M 8	75	120	12	50	75	75
61931.W0100	M 8	75	120	12	50	100	100
61931.W0125	M 8	75	120	12	50	125	125
61931.W0150	M12	120	160	16	80	150	150
61931.W0200	M12	120	160	16	80	200	200
61931.W0250	M12	120	160	16	80	250	250
61931.W0350	M12	120	160	16	80	350	350
61931.W0500	M14	140	180	18	100	500	500
61931.W0750	M14	140	180	18	100	750	750