

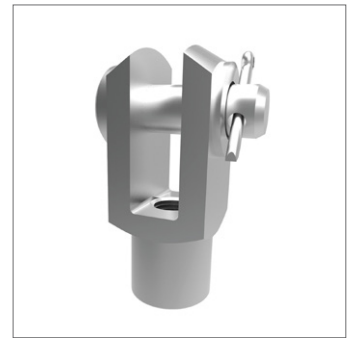

Steel Clevis Joint with Pin

silver zinc plated

Clevis Joints

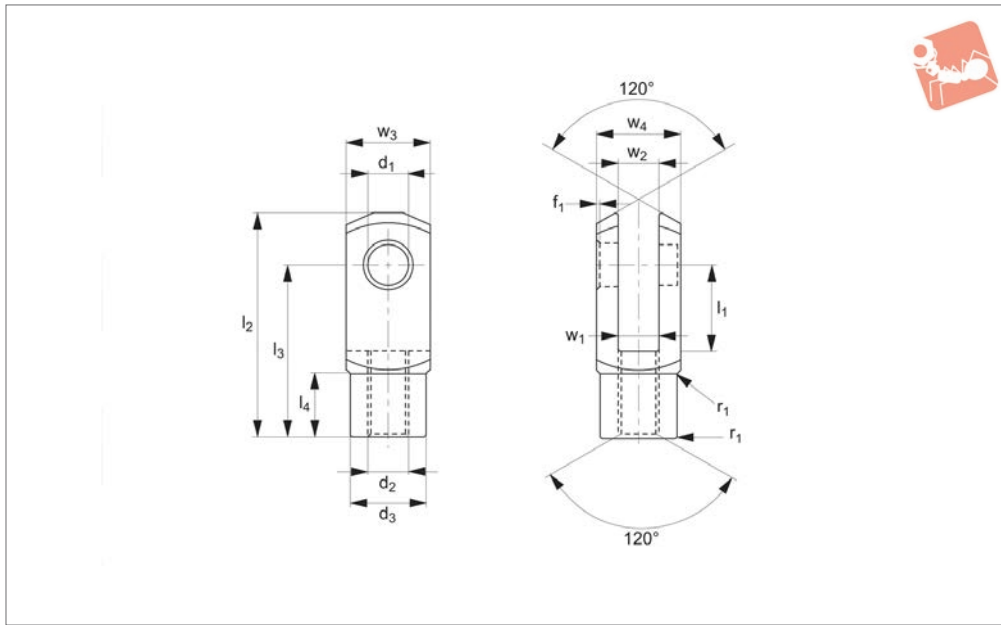

65600

CLEVIS JOINTS

Material

Steel 1.0718 (11SMnPb30k), silver zinc plated.

Technical Notes

M5-M16: DIN 71 752/DIN ISO 8140.
M18-M48: Similar to DIN 71 752/DIN ISO 8140 and according to CETOP standard.

Tips

Standard thread is right hand, (for left hand, see 65602).
Assembly is made up using 65630 clevis

joint, 65660 clevis pin, P0330 washer, and 65674 split cotter pin.

Important Notes

For sizes M4-M12, f_1 and $r_1 = 0,5$, for sizes M14-M16, f_1 and $r_1 = 1$
For sizes M18-M20, $f_1 = 1$, $r_1 = 1,5$, for M24 f_1 and $r_1 = 1,5$, for sizes M27-M30, $f_1 = 1,5$, $r_1 = 2$
For M36 $f_1 = 2$, $r_1 = 3$, for sizes M42-M48, $f_1 = 3$, $r_1 = 5$, for r_1 , radius or 45° bevelling.
Other Tolerances:-

w_4 : M4-M16 = +0,3 -0,16
M18-M48 = +0,5 -0,2
 w_2 : size 4x8-10x20 = B13
All others +0,7 +0,15
 d_3 : M4-M16 = ±0,3
 l_2 : size 4x8-6x12 = ±0,3
All others ±0,4
 l_3 : M4-M16 = ±0,2
M18-M48 = ±0,3
 r_1 : M18-M48 = ±0,5

Order No.	Size	Thread hand	Thread type	d_1 tol. H9	l_1 ±0.5	d_2	d_3	l_2 ±0.5	l_3	l_4	w_1 tol. B13	w_2	w_3 tol. h11	w_4	Weight g
65600.W0051	5x10	Right	Coarse	5	10	M5	9	26	20	7.5	5	5	10	10	9
65600.W0052	5x20	Right	Coarse	5	20	M5	9	36	30	7.5	5	5	10	10	13
65600.W0061	6x12	Right	Coarse	6	12	M6	10	31	24	9.0	6	6	12	12	15
65600.W0062	6x24	Right	Coarse	6	24	M6	10	43	36	9.0	6	6	12	12	21
65600.W0081	8x16	Right	Coarse	8	16	M8	14	42	32	12.0	8	8	16	16	37
65600.W0082	8x16	Right	Fine	8	16	M8x1	14	42	32	12.0	8	8	16	16	37
65600.W0083	8x32	Right	Coarse	8	32	M8	14	58	48	12.0	8	8	16	16	54
65600.W0084	8x32	Right	Fine	8	32	M8x1	14	58	48	12.0	8	8	16	16	54
65600.W0102	10x20	Right	Coarse	10	20	M10	18	52	40	15.0	10	10	20	20	74
65600.W0103	10x20	Right	Fine	10	20	M10x1,25	18	52	40	15.0	10	10	20	20	74
65600.W0104	10x40	Right	Coarse	10	40	M10	18	72	60	15.0	10	10	20	20	116
65600.W0105	10x40	Right	Fine	10	40	M10x1,25	18	72	60	15.0	10	10	20	20	116
65600.W0122	12x24	Right	Coarse	12	24	M12	20	62	48	18.0	12	12	24	24	121
65600.W0123	12x24	Right	Fine	12	24	M12x1,25	20	62	48	18.0	12	12	24	24	121
65600.W0124	12x48	Right	Coarse	12	48	M12	20	86	72	18.0	12	12	24	24	175
65600.W0125	12x48	Right	Fine	12	48	M12x1,25	20	86	72	18.0	12	12	24	24	175
65600.W0142	14x28	Right	Coarse	14	28	M14	24	72	56	22.5	14	14	27	27	178
65600.W0143	14x28	Right	Fine	14	28	M14x1,5	24	72	56	22.5	14	14	27	27	178
65600.W0145	14x56	Right	Coarse	14	56	M14	24	101	85	22.5	14	14	27	27	258
65600.W0146	14x56	Right	Fine	14	56	M14x1,5	24	101	85	22.5	14	14	27	27	258
65600.W0163	16x32	Right	Coarse	16	32	M16	26	83	64	24.0	16	16	32	32	282
65600.W0164	16x32	Right	Fine	16	32	M16x1,5	26	83	64	24.0	16	16	32	32	282
65600.W0166	16x64	Right	Coarse	16	64	M16	26	115	96	24.0	16	16	32	32	411
65600.W0167	16x64	Right	Fine	16	64	M16x1,5	26	115	96	24.0	16	16	32	32	411
65600.W0183	18x36	Right	Coarse	18	36	M18	30	94	72	27.0	18	18	36	36	390



Order No.	Size	Thread hand	Thread type	d ₁ tol. H9	l ₁ ±0.5	d ₂	d ₃	l ₂ ±0.5	l ₃	l ₄	w ₁ tol. B13	w ₂	w ₃ tol. h11	w ₄	Weight g
65600.W0184	18x36	Right	Fine	18	36	M18x1,5	30	94	72	27.0	18	18	36	36	390
65600.W0204	20x40	Right	Coarse	20	40	M20	34	105	80	30.0	20	20	40	40	550
65600.W0205	20x40	Right	Fine	20	40	M20x1,5	34	105	80	30.0	20	20	40	40	550
65600.W0208	20x80	Right	Coarse	20	80	M20	34	145	120	30.0	20	20	40	40	800
65600.W0209	20x80	Right	Fine	20	80	M20x1,5	34	145	120	30.0	20	20	40	40	800
65600.W0255	25x50	Right	Course	25	50	M24	42	132	100	36.0	25	25	50	50	1100
65600.W0256	25x50	Right	Fine	25	50	M24x2	42	132	100	36.0	25	25	50	50	1100
65600.W0285	28x56	Right	Coarse	28	56	M27	48	148	112	40.0	28	28	55	55	1500
65600.W0286	28x56	Right	Fine	28	56	M27x2	48	148	112	40.0	28	28	55	55	1500
65600.W0305	30x54	Right	Fine	30	54	M27x2	48	148	110	40.0	30	30	55	55	1440
65600.W0306	30x60	Right	Coarse	30	60	M30	52	160	120	42.0	30	30	60	60	1970
65600.W0307	30x60	Right	Fine	30	60	M30x2	52	160	120	42.0	30	30	60	60	1970
65600.W0355	35x54	Right	Fine	35	54	M36x2	60	188	144	54.0	35	35	70	70	2930
65600.W0357	35x72	Right	Coarse	35	72	M36	60	188	144	54.0	35	35	70	70	2930
65600.W0358	35x72	Right	Fine	35	72	M36x2	60	188	144	54.0	35	35	70	70	2930
65600.W0367	36x72	Right	Coarse	35	72	M36	60	188	144	54.0	36	36	70	70	2930
65600.W0368	36x72	Right	Fine	35	72	M36x2	60	188	144	54.0	36	36	70	70	2930
65600.W0408	40x84	Right	Fine	40	84	M42x2	70	232	168	63.5	40	40	85	85	5640
65600.W0428	42x84	Right	Coarse	42	84	M42	70	232	168	63.5	42	42	85	85	5340
65600.W0429	42x84	Right	Fine	42	84	M42x2	70	232	168	63.5	42	42	85	85	5340
65600.W0509	50x96	Right	Coarse	50	96	M48	82	265	192	73.0	50	50	96	96	7860
65600.W0510	50x96	Right	Fine	50	96	M48x2	82	265	192	73.0	50	50	96	96	7860



Parts overview

Clevis Joints

Stocked to DIN 71752 in steel and stainless steel. Plain clevis joints available in right and left hand threads zinc plated steel and stainless steel. Steel sizes from M4 up to M48. Stainless sizes from M4 up to M27.



Clevis Mating Pieces

These are designed to fit in between our clevis joints to create a linkage where an angular offset is required. Available in zinc plated steel and stainless steel. Sizes M4 up to M20.



Clevis Pins and Clips

Various styles of pins and clips to suit clevis joints in zinc plated steel and stainless steel. Sizes available to suit all sizes of clevis joints that we offer.



Clevis Retention Clips

These are the most popular type of clip used with our clevis joints. They create a neat compact assembly, only available in zinc plated steel. Size available for clevis joints from 4mm up to 20mm.



Male Clevis Joints

Stocked in zinc plated steel and stainless steel, right and left hand threads. Sizes M6 up to M20.





Zinc plated steel

Clevis with retention clip
65630 and 65684



Clevis with clevis pin 65664
Safety fastener 65680

Clevis with clevis pin,
washer and cotter pin
65660 and 65674



Stainless steel

Clevis with clevis pin
and circlips 65666
and 65678



Clevis with clevis pin,
washer and cotter pin
65661 and 65675



Assembly options

Clevis with 65652
mating piece
and 65684 clevis
retention clip



Clevis with 65880
rod end and 65684
clevis retention clip



Tensile tests, statistically to failure (break)

Clevises M6 - M42

Clevis joints axially loaded.

Material

Leaded low carbon steel (AISI 12L14, 1.0718).

Important note: values in this table are indicative only and should only be used as a rough guide. The Company cannot foresee the intended applications of their products and we accept no liability for any actions taken by third parties. Customers are advised to use their own safety factors and/or perform their own testing on the clevis joint to ensure it meets requirements for their application.

Clevis size	F min (kN)	F max (kN)	F average value (kN)	Avg. force when clevis starts to deform (kN)
6 x 24 M 6	16,0	19,5	17,6	15,3
8 x 32 M 8	33,2	35,6	34,6	29,3
10 x 40 M10	42,0	52,0	47,5	41,3
12 x 48 M12	53,0	68,5	61,1	50,2
14 x 56 M14	60,5	64,5	63,0	48,8
16 x 64 M16	133,5	146,0	140,2	115
20 x 40 M20	194,5	234,0	213,5	176
25 x 50 M25	311,0	336,0	328,0	260
30 x 60 M30	428,0	450,0	440,6	343
36 x 72 M36	566,0	573,0	569,5	300
35 x 72 M36	561,2	567,9	564,6	370
42 x 84 M42	904,6	904,6	904,6	420