

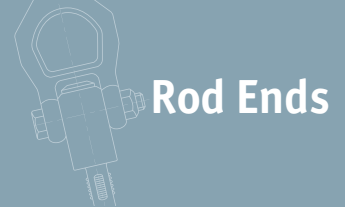

# Lock Nuts Coarse Thread

## A2 stainless



### Rod Ends

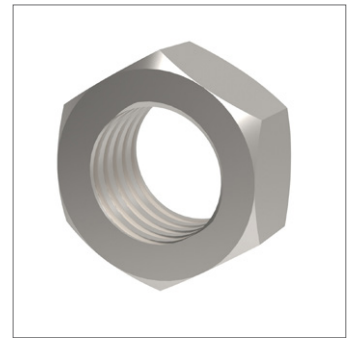
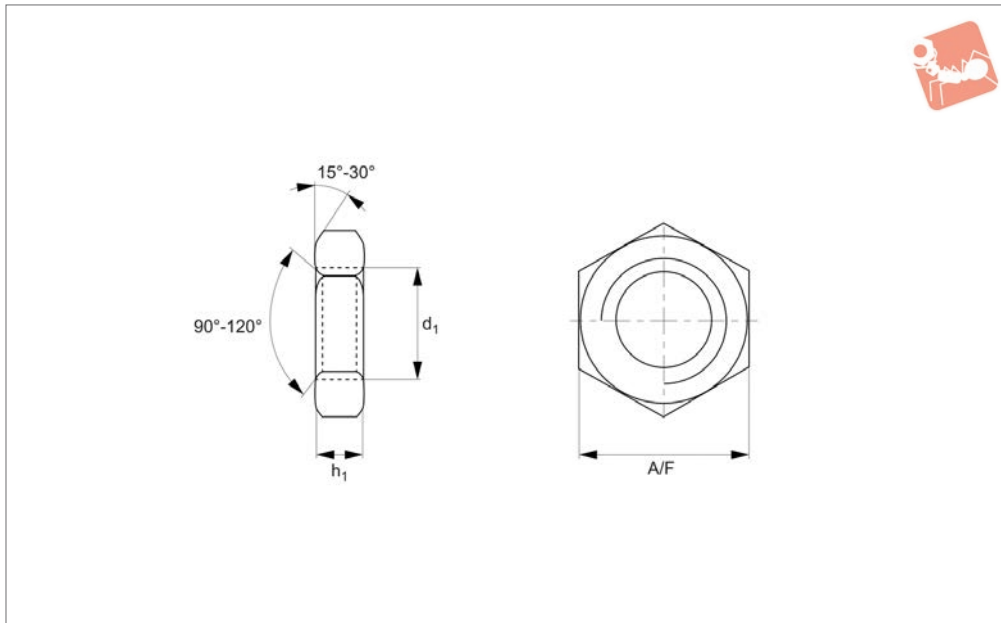

## 65690.A2

ROD ENDS

#### Material

Stainless steel (A2).

#### Technical Notes

To DIN 439. Standard metric coarse pitch threads.

Order No.	d <sub>1</sub>	h <sub>1</sub>	A/F	Material
65690.016-A2	M1,6	0.75	3.2	A2 s/s
65690.017-A2	M1,7	0.75	3.5	A2 s/s
65690.020-A2	M 2	0.95	4	A2 s/s
65690.023-A2	M2,3	0.95	4.5	A2 s/s
65690.025-A2	M2,5	1.35	5	A2 s/s
65690.026-A2	M2,6	1.35	5	A2 s/s
65690.030-A2	M 3	1.55	5.5	A2 s/s
65690.040-A2	M 4	1.95	7	A2 s/s
65690.050-A2	M 5	2.45	8	A2 s/s
65690.060-A2	M 6	2.9	10	A2 s/s
65690.080-A2	M 8	3.7	13	A2 s/s
65690.100-A2	M10	4.7	17	A2 s/s
65690.120-A2	M12	5.7	19	A2 s/s
65690.140-A2	M14	6.42	22	A2 s/s
65690.160-A2	M16	7.42	24	A2 s/s
65690.180-A2	M18	8.42	27	A2 s/s
65690.200-A2	M20	9.1	30	A2 s/s
65690.220-A2	M22	9.9	34	A2 s/s
65690.240-A2	M24	10.9	36	A2 s/s
65690.270-A2	M27	12.4	41	A2 s/s
65690.300-A2	M30	13.9	46	A2 s/s
65690.330-A2	M33	15.4	50	A2 s/s
65690.360-A2	M36	16.9	55	A2 s/s
65690.420-A2	M42	19.7	65	A2 s/s
65690.480-A2	M48	22.7	75	A2 s/s