

# Cranked Handles

straight - DIN 469

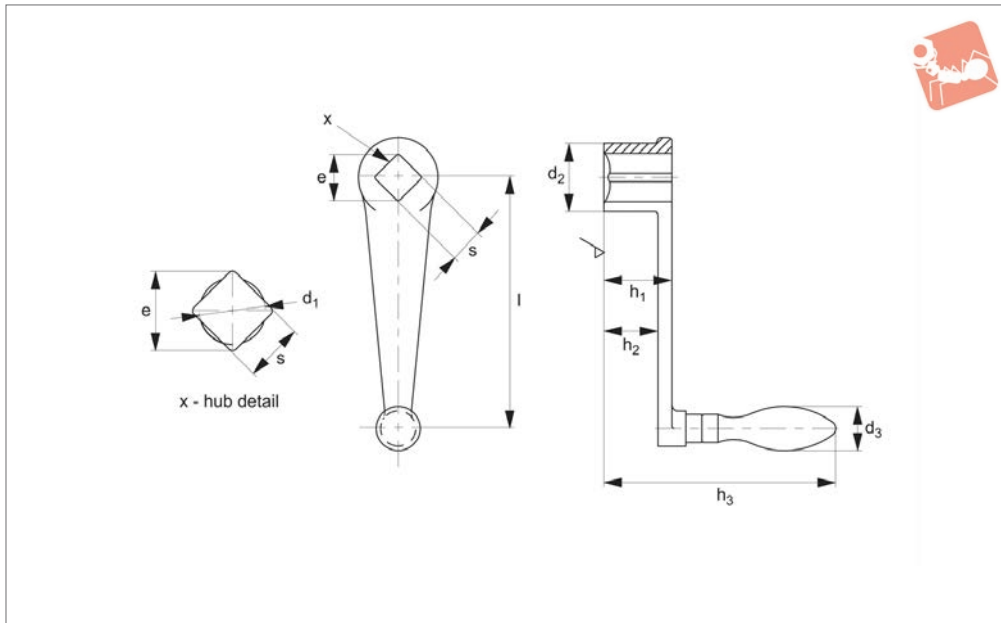
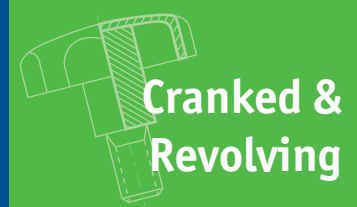

**75200**

CRANKED & REVOLVING HANDLES

### Material

Size 63 - malleable cast iron.

Size 80-250 - nodular cast iron.

Deburred, sand blasted and black plastic

coated.

Handle body: cast iron (GTW), plastic coated, black.

For corresponding handle details see

no.75060 (non-removable).

Hub-machined, with square bore details to DIN 79.

Order No.	Finish	Size l	s tol. H11	e min.	d <sub>1</sub>	d <sub>2</sub>	h <sub>1</sub>	h <sub>2</sub> ≈	h <sub>3</sub>	Corresp. handle dia. d <sub>3</sub>	Weight g
75200.W0006	Fixed Handle	63	10	13.1	10.5	20	20	15	74	16	109
75200.W0008	Fixed Handle	80	10	13.1	10.5	24	24	18	94	18	183
75200.W0010	Fixed Handle	100	12	16.1	12.6	28	28	21	98	20	278
75200.W0012	Fixed Handle	125	14	18.1	14.7	34	34	26	120	22	444
75200.W0016	Fixed Handle	160	17	22.2	17.9	38	38	29	122	25	649
75200.W0020	Fixed Handle	200	19	25.2	20.0	44	44	34	154	28	962
75200.W0025	Fixed Handle	250	22	28.2	23.1	48	48	36	157	32	1360
75200.W0108	Fixed Handle	80	12	16.1	12.6	24	24	18	94	18	186
75200.W0110	Fixed Handle	100	14	18.1	14.7	28	28	21	98	20	259
75200.W0112	Fixed Handle	125	17	22.2	17.9	34	34	26	120	22	433
75200.W0116	Fixed Handle	160	19	25.2	20.0	38	38	29	122	25	633
75200.W0120	Fixed Handle	200	22	28.2	23.1	44	44	34	154	28	983
75200.W0125	Fixed Handle	250	24	32.2	25.3	48	48	36	157	32	1351
75200.W0506	Rotating Handle	63	10	13.1	10.5	20	20	15	79	16	118
75200.W0508	Rotating Handle	80	10	13.1	10.5	24	24	18	97	18	194
75200.W0510	Rotating Handle	100	12	16.1	12.6	28	28	21	100	20	272
75200.W0512	Rotating Handle	125	14	18.1	14.7	34	34	26	122	22	468
75200.W0516	Rotating Handle	160	17	22.2	17.9	38	38	29	126	25	667
75200.W0520	Rotating Handle	200	19	25.2	20.0	44	44	34	160	28	1054
75200.W0525	Rotating Handle	250	22	28.2	23.1	48	48	36	162	32	1441
75200.W0608	Rotating Handle	80	12	16.1	12.6	24	24	18	97	18	197
75200.W0610	Rotating Handle	100	14	18.1	14.7	28	28	21	100	20	280
75200.W0612	Rotating Handle	125	17	22.2	17.9	34	34	26	122	22	433
75200.W0616	Rotating Handle	160	19	25.2	20.0	38	38	29	126	25	651
75200.W0620	Rotating Handle	200	22	28.2	23.1	44	44	34	160	28	992
75200.W0625	Rotating Handle	250	24	32.2	25.3	48	48	36	162	32	1409