

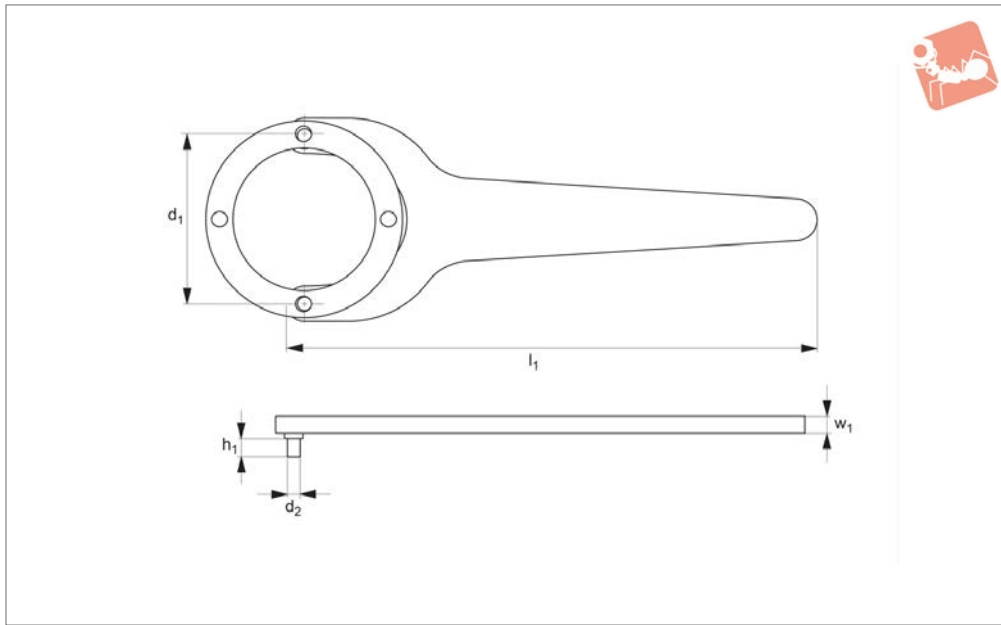

Face Spanner - with Pins fixed

Spanners & Hook Spanners



95340

SPANNERS & HOOK SPANNERS

Material

Steel (C35/C45), tempered and blackened.

Pins spot welded.

Tips

()= not to DIN standard.

Technical Notes

Produced to DIN 3116A.

Order No.	d ₁ for nut Ø	d ₂ -0.1 tol. h12	h ₁	l ₁	w ₁	Weight g
95340.W0013	13	2.5	3.0	90	3	27
95340.W0015	15	3.0	3.5	90	3	27
95340.W0020	(20)	3.0	4.0	122	4	50
95340.W0021	(20)	4.0	5.0	122	4	50
95340.W0025	25	3.0	4.0	137	4	65
95340.W0026	(25)	4.0	5.0	137	4	65
95340.W0030	30	4.0	5.0	164	4	85
95340.W0035	35	5.0	6.0	180	5	120
95340.W0036	(35)	4.0	5.0	180	5	120
95340.W0040	40	4.0	5.0	167	5	120
95340.W0045	45	4.0	5.0	187	5	145
95340.W0050	50	5.0	6.0	198	5	175
95340.W0060	60	5.0	6.0	213	6	220
95340.W0075	75	6.0	7.0	243	6	330
95340.W0090	90	7.0	7.5	270	6	410