

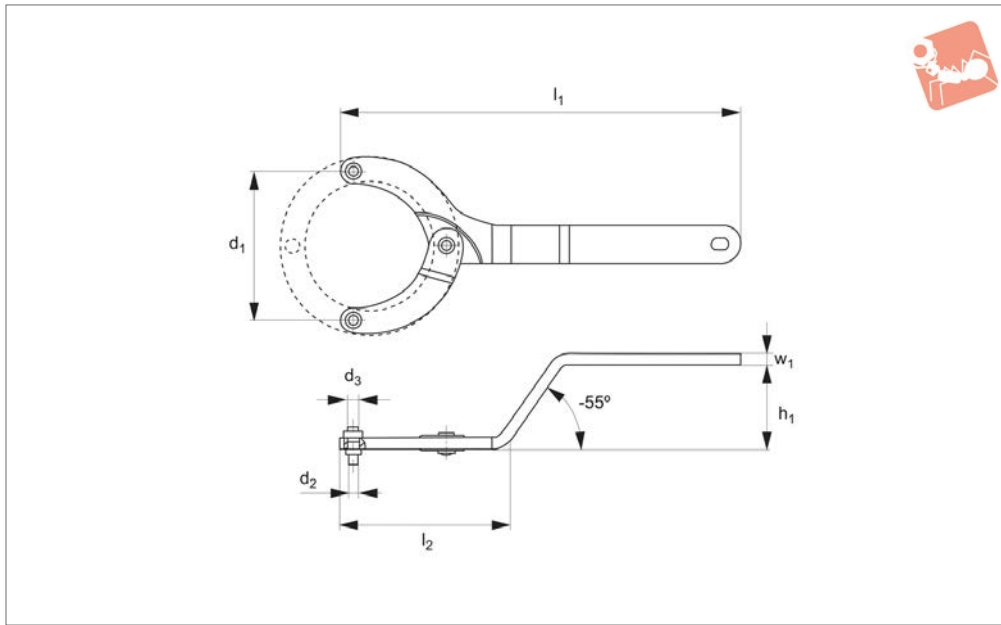

Adjustable Face Spanner - Cranked with replaceable pins

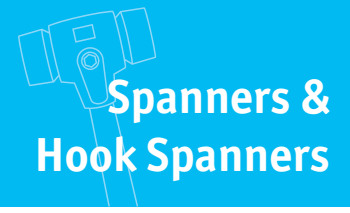

95353

SPANNERS & HOOK SPANNERS

Material

Spanner: steel C35/C45, hardened, with blue finish.

Pins: hardened steel, blackened.

(tolerance class h12). See part 95360 for replacement pins.

Technical Notes

Pin diameter = nominal diameter -0,1mm

Order No.	d ₁ for nut Ø	d ₂ -0.1	d ₃	h ₁	l ₁	l ₂	w ₁	Weight g
95353.W0041	18-40	3	M 4	33	158	57	5	114
95353.W0042	18-40	4	M 4	33	158	57	5	114
95353.W0081	40-80	4	M 6	45	215	92	6	290
95353.W0082	40-80	5	M 6	45	215	92	6	290
95353.W0083	40-80	6	M 6	45	215	92	6	295
95353.W0125	80-125	6	M 6	63	290	130	8	695
95353.W0126	80-125	8	M 6	63	290	130	8	700