

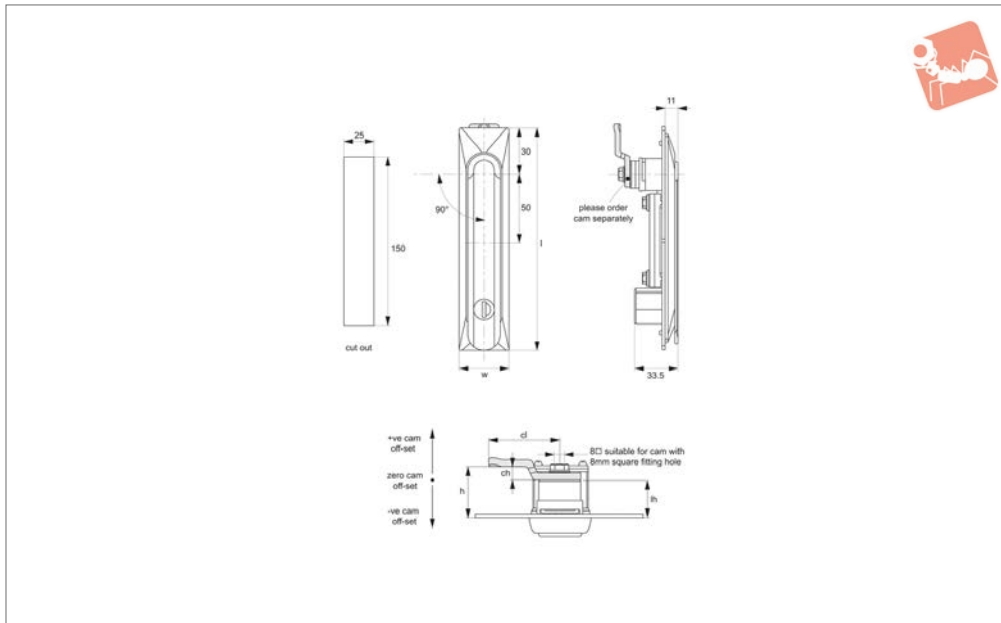

# Swing Handles - Cam Control

standard cylinder lock - zinc

## Swing Handles



**B1180**

SWING HANDLES

### Material

Body & Handle: die cast zinc, pocked black power coated.

Polyurethane gasket: to achieve IP65 rating.

Cylinder lock: die cast zinc, chrome plated.

**Supplied with:** Keys: two per lock.

**Not supplied:** Cam: order separately.

### Technical Notes

Order cam separately.

**Cams:** see suitable cam A0203, A0224 and A0240. Select „without projection“ cam type.

Dimensions ch and cl relate to cam. Use formula to calculate ch (required cam off-set), and refer to cam selection chart;

**ch = h - lh** where;

**ch** = required cam off-set/height.

**h** = grip length (distance between inside of latch face and front of cam).

**lh** = body length of cam latch/lock to be used (see product table below).

**Rods & Guides:** to achieve 3-point latching - A0303, A0321, A0325.

Order No.	Finish	Lock type	Key type	l	w	lh
<b>B1180.AW0010</b>	Black Coated	Std. Cylinder	Keyed Alike	160	36	20