

Index Plungers - Precision

cylindrical pin

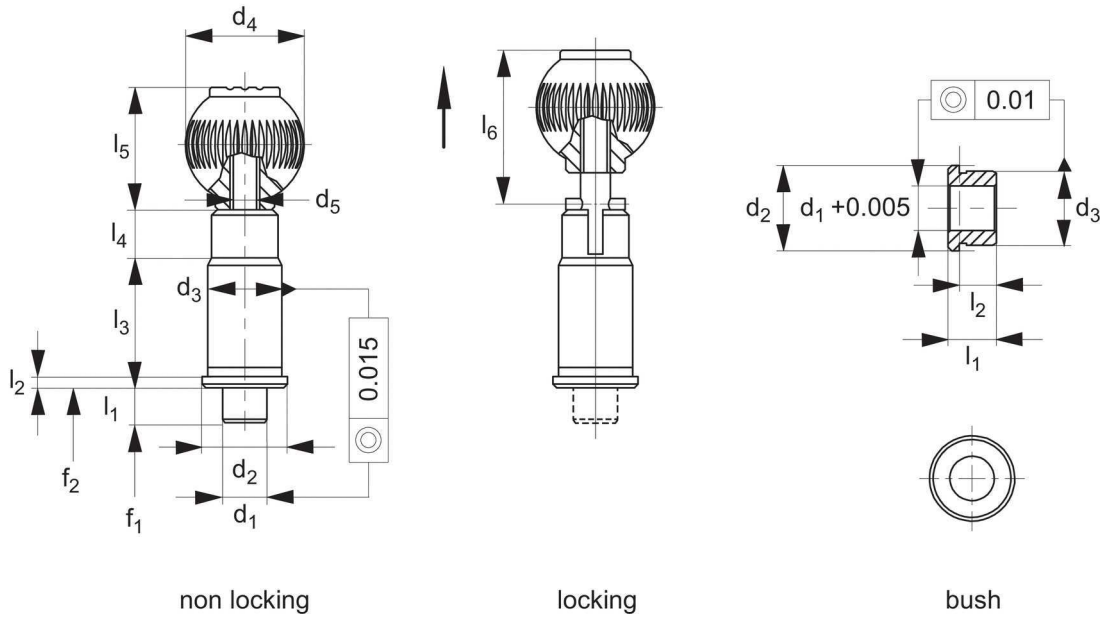

32460



Order No.	Type	d ₁ -0,005 -0,01	d ₂	d ₃ n6	d ₄	d ₅	l ₁ min.	l ₂	l ₃	l ₄	l ₅	l ₆	Sprin		g
													g load*	g load*	
32460.W0010	Non Locking	10	19	16	25	M 6	10	2,5	31	13	25,0	-	15	30	79
32460.W0012	Non Locking	12	23	20	32	M 8	10	3,0	35	13	33,0	-	15	35	138
32460.W0016	Non Locking	16	28	25	40	M10	10	3,0	42	13	41,5	-	20	50	226
32460.W0020	Non Locking	20	33	30	40	M10	10	3,0	50	13	41,5	-	36	63	350
32460.W0025	Non Locking	25	42	38	50	M10	10	3,0	60	13	51,0	-	20	73	649
32460.W0060	Locking	10	19	16	25	M 6	10	2,5	31	13	25,0	36,5	15	30	79
32460.W0062	Locking	12	23	20	32	M 8	10	3,0	35	13	33,0	44,5	15	35	136
32460.W0066	Locking	16	28	25	40	M10	10	3,0	42	13	41,5	53,0	20	50	228
32460.W0070	Locking	20	33	30	40	M10	10	3,0	50	13	41,5	53,0	36	63	350
32460.W0075	Locking	25	42	38	50	M10	10	3,0	60	13	51,0	62,5	20	73	649
32460.W0090	Bush	10	19	16	-	-	11	8,5	-	-	-	-	-	-	11
32460.W0092	Bush	12	23	20	-	-	13	10,0	-	-	-	-	-	-	22
32460.W0093	Bush	16	28	25	-	-	17	14,0	-	-	-	-	-	-	40
32460.W0094	Bush	20	33	30	-	-	16	13,0	-	-	-	-	-	-	51
32460.W0096	Bush	25	42	38	-	-	19	16,0	-	-	-	-	-	-	99

Material

Pin, Body & Bush: case-hardened steel, blackened and ground.
Grip: thermoplastic, black.

Technical Notes

Supplied part assembled to enable precise setting, grip and body must be glued after mounting. Non removable once installed.

"Locking" type - enable pin to be held in retracted/non-projecting position; pull back grip, turn 90 to engage 'locking' on a notched catch.

"Non Locking" type - pin simply springs back when grip released.

Tips

When used for alignment of two sub-plates, the plunger's precise finish guarantees high repetition accuracy.

Spring loads * = statistical average.



Index Plungers - Precision

tapered pin



32480

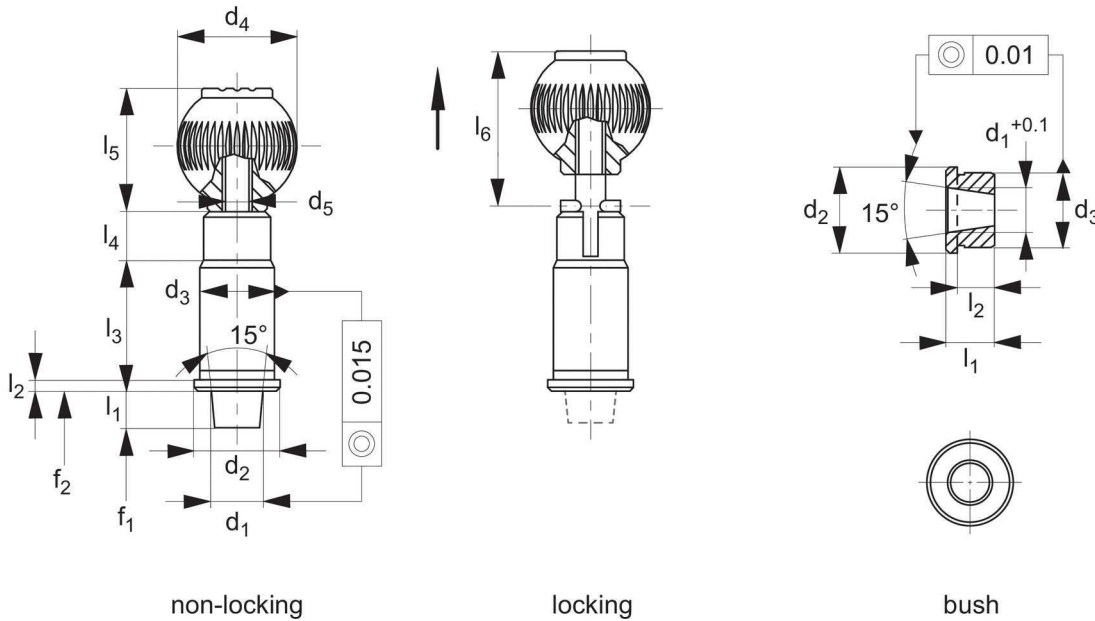

Order No.	Type	No m. dia.	d_1	d_2	d_3 n6	d_4	d_5	l_1 min.	l_2	l_3	l_4	l_5	l_6	Spring load *	Spring load *	f_1 N	f_2 N	g
32480.W0110	Non Locking	10	10,00	19	16	25	M 6	6	2,5	31	13	25,0	-	19	29	78		
32480.W0112	Non Locking	12	12,00	23	20	32	M 8	6	3,0	35	13	33,0	-	22	35	135		
32480.W0116	Non Locking	16	16,00	28	25	40	M10	6	3,0	42	13	41,5	-	30	50	227		
32480.W0120	Non Locking	20	20,00	33	30	40	M10	6	3,0	50	13	41,5	-	46	63	348		
32480.W0125	Non Locking	25	25,00	42	38	50	M10	6	3,0	60	13	51,0	-	39	73	654		
32480.W0160	Locking	10	10,00	19	16	25	M 6	6	2,5	31	13	25,0	32,5	19	29	78		
32480.W0162	Locking	12	12,00	23	20	32	M 8	6	3,0	35	13	33,0	40,5	22	35	135		
32480.W0166	Locking	16	16,00	28	25	40	M10	6	3,0	42	13	41,5	49,0	30	50	228		
32480.W0170	Locking	20	20,00	33	30	40	M10	6	3,0	50	13	41,5	49,0	46	63	348		
32480.W0175	Locking	25	25,00	42	38	50	M10	6	3,0	60	13	51,0	58,5	39	73	651		
32480.W0190	Tapered Bush	10	7,10	19	16	-	-	11	8,5	-	-	-	-	-	-	13		
32480.W0192	Tapered Bush	12	8,28	23	20	-	-	13	10,0	-	-	-	-	-	-	25		
32480.W0193	Tapered Bush	16	11,52	28	25	-	-	17	14,0	-	-	-	-	-	-	47		
32480.W0194	Tapered Bush	20	15,49	33	30	-	-	16	13,0	-	-	-	-	-	-	60		
32480.W0196	Tapered Bush	25	19,70	42	38	-	-	19	16,0	-	-	-	-	-	-	114		

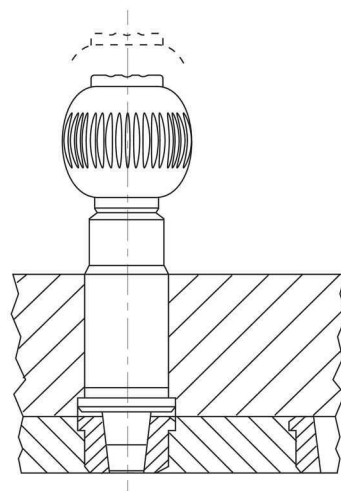

Material

Pin, body & bush: case hardened steel, blackened and ground.
Grip: thermoplastic, black.

Technical Notes

Supplied part assembled to enable precise setting, grip and body must be glued after mounting. Non removable once installed.

"Locking" type - enable pin to be held in retracted/non-projecting position; pull back grip, turn 90° to engage 'locking' on a notched catch.

"Non Locking" type - pin simply springs back when grip released.

Tips

When used for alignment of two sub-plates, the plunger's precise finish on pin allows easier alignment of pin and bushing.
Spring loads * = statistical average.



A wide selection of solutions

- Locating and positioning.
- Indexing.
- Securing.
- Positive locking.
- Rapid adjustment of all kinds of tables, platforms and fixtures.
- Machine and fixture design.
- OEM products.
- Sports equipment.
- Medical aides (wheelchairs etc.).
- Aerospace.
- Machine cabinets.

Applications



Steel with plastic grip



Stainless with plastic grip



Stainless body and grip

Materials



Locking (park)



Non locking (spring back)

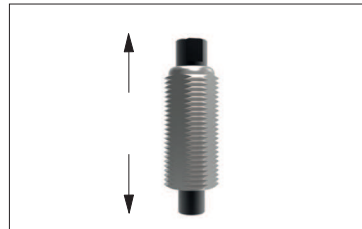

Push pull

Locking or non locking



Standard grip



Lever grip



T-handle



Pull ring



Threaded for bespoke handle

Handling and actuation methods



Fine threaded (standard)



Coarse thread



Flange mount



Thin wall mount



Weldable

Mounting options

- Unless otherwise stated, grips on index plungers are not removeable.
- Many of the pins on index plungers are toleranced to either the pin or the hole. Please refer to the specific product table.
- Index plungers are not recommended for shear load applications.

Pin Tol. Hole Tol.

①	h_9	+0,03 +0,08
②	-0,02 -0,04	H ₇

Additional technical notes

- s** Stroke, or movement of plunger's pin.
- f₁** The force required in Newtons (N) to over come the static strength of the spring and achieve initial movement of the plunger's pin.
- f₂** The force required in Newtons (N) to fully compress the spring until the pin is fully depressed against the plunger's body.

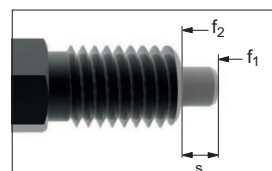

Spring loads

Computing the strength of index plungers

for shear loads / flexure loads of the plunger pin



Flexure loads

As soon as a gap l exists between the mounting plate in which the index plunger is installed, and the mating or base plate, the load must be considered to be as per a flexure load, with rod clamped at one side.

With this approach, the calculation is made against the bending of the index plunger.

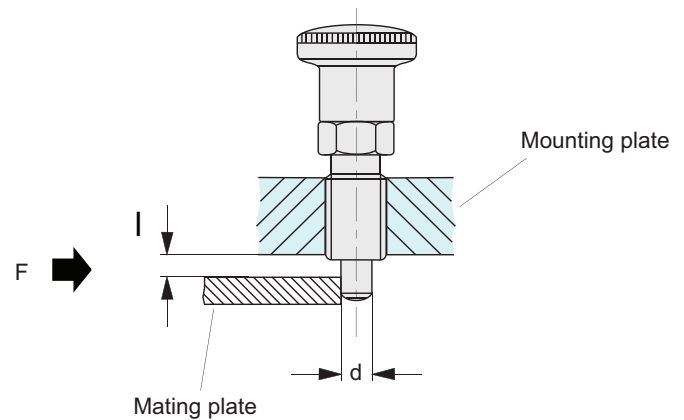

Formulas for computation

Resistance torque

$$W = \frac{\pi \times d^3}{32}$$

Flexural stress

$$M_b = \sigma_b \times W$$

Flexural strength

$$F = \frac{M_b}{l} = \frac{\sigma_b \times \pi \times d^3}{l \times 32}$$

Material characteristics

The yield or substitute yield limit ($R_e / R_p 0,2$) shown in the table opposite has been determined in tension tests involving tension specimen in accordance with DIN 50125-B6-30.

These tests constitute the basis for the load bearing details given.

Material Description	Material no.	R_e in N/mm ² (= per. flexural tension σ_b)
C45Pb	1.0504	560
X 10 CrNiS 18 9A	ISI 303	580

Calculation example, load values

Example:

Index plungers with a bolt diameter of 5 mm made of steel with a yield limit of $R_e = 560 \text{ N/mm}^2$, calculation against permanent deformation, the maximum permissible flexural strength is calculated as:

$$F_{\text{per}} = \frac{560 \text{ N/mm}^2 \times \pi \times (5\text{mm})^3}{2\text{mm} \times 32} = 3430 \text{ N}$$

d Bolt diameter	max. flexural strength F in N, acc. to material and gap l differentiated			
	C45Pb/1.0504		X 10 CrNiS 18 9/1.4305	
	$l = 2 \text{ mm}$	$l = 3 \text{ mm}$	$l = 2 \text{ mm}$	$l = 3 \text{ mm}$
3	740	490	760	510
4	1750	1170	1820	1210
5	3430	2290	3550	2370
6.5	930	3950	6140	4100
8	14070	9380	14570	9710
10	27480	18320	28470	18980
12	47490	31660	49190	32790
16	90070	102940	93290	119020

Safety information

On principle, the design also needs an adequate safety coefficient to be taken into account. The usual safety coefficients under static load 1.2 to 1.5; pulsating 1.8 to 2.4 and alternating 3 to 4.

Disclaimer:

You should carry out your own test series to verify whether a certain product is suitable for your specific applications.

Computing the strength of index plungers

for shear loads / flexure loads of the plunger pin



Shear loads

Providing only a very small gap exists between the mounting plate in which the index plunger is installed, and the mounting plate or base plate, the load can be calculated as a clean shear action.

As this is normally not the case, the "flexure" load should be used - see following page.

Approximately 80 % of the bolt's tensile strength is assumed for the shear strength. This approach calculates against the tensile strength R_m , i.e. against the index pin shearing off.

To ensure the permanent and proper function of the index plunger, the yield limit R_e must be considered in place of the tensile strength R_m .

Stop using the index plunger if the pin is damaged or deformed.

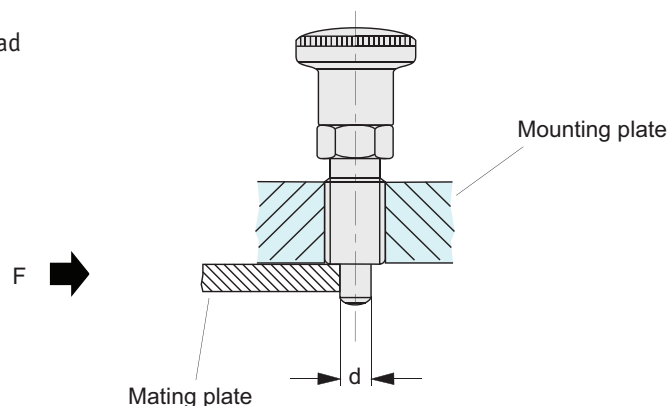

Formulas for computation

Bolt cross-section

$$S = \frac{d^2 \times \pi}{4}$$

Limit tension

$$\tau_a = 0,8 \times R_m$$

Shear force

$$F = S \times \tau_a = \frac{d^2 \times \pi}{4} \times 0,8 \times R_m$$

Material characteristics

The tensile strength shown in the table opposite (R_m) and the yield or substitute yield limit ($R_e / R_p 0,2$) have been determine in tension tests involving tension specimen in accordance with DIN 50125- B6-30

These tests constitute the basis for the load bearing details given.

Material Description	Material no.	R_e in N/mm ²	R_m in N/mm ²
C45Pb	1.0504	560	640
X 10 CrNiS 18 9A	ISI 303	580	740

Calculation example, load values

Example:

Index plungers with a bolt diameter of 6 mm made of Stainless Steel with a yield limit of $R_e = 580 \text{ N/mm}^2$, calculation against permanent deformation, the maximum permissible shear stress is calculated as:

$$F_{per} = \frac{(6 \text{ mm})^2 \times \pi}{4} \times 0,8 \times 580 \text{ N/mm}^2 = 13120 \text{ N}$$

d Bolt diameter	max. force F in N, acc. to material and strength value differs			
	C45Pb/1.05045		X 10 CrNiS 18 9/1.4305	
	at R_e	at R_m	at R_e	at R_m
3	3160	3610	3270	4180
4	5620	6430	5830	7430
5	790	10050	9110	11620
6	12660	14470	13120	16730
8	22510	25730	23320	29750
10	35180	40210	36440	46490
12	50660	57900	52470	66950
16	90070	102940	93290	119020

Safety information

On principle, the design also needs an adequate safety coefficient to be taken into account. The usual safety coefficients under static load 1.2 to 1,5; pulsating 1.8 to 2.4 and alternating 3 to 4.

Disclaimer:

You should carry out your own test series to verify whether a certain product is suitable for your specific applications.