

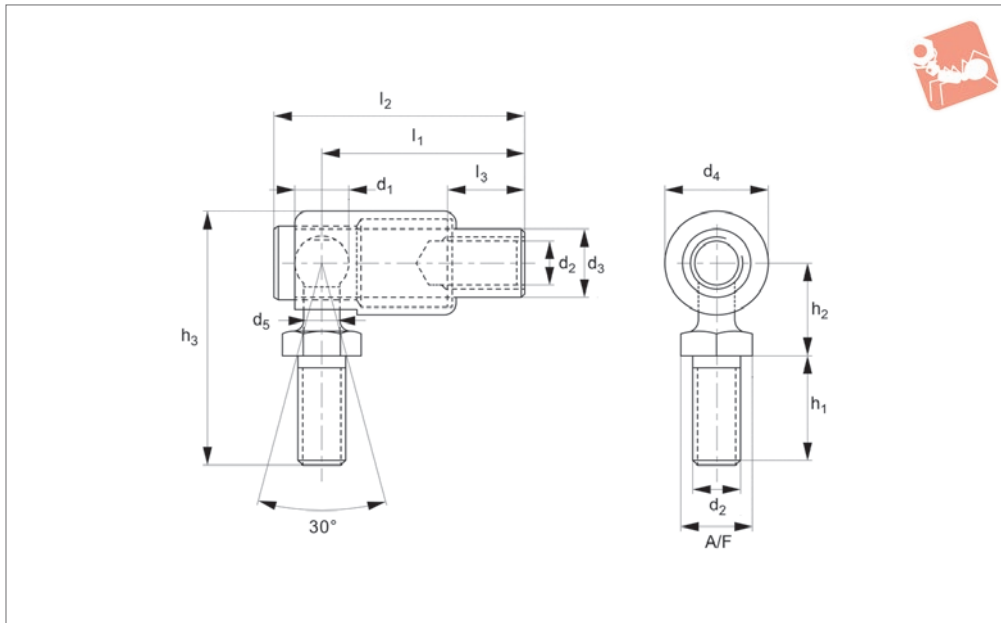

Quick Release Ball Joints

A2 stainless and steel, zinc-plated

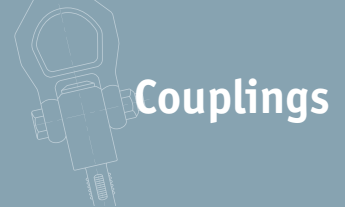

65542

COUPLINGS

Material

Body: stainless steel (A2, AISI 303) or steel zinc-plated.

Shield and ball stud: carbon steel.

Body and ball stud: case hardened.

Spring: (302 S26) stainless steel or equivalent, zinc plated.

Technical Notes

The spring loaded outer shield allows both rapid release and reconnection of the ball stud.

Linkage assemblies can be installed or removed without disturbing pre-set centres.

These are metric equivalents to SAE J 490 Style 1 quick release detachable ball joints.

Tips

Standard thread is a right hand thread.

Order No.	Thread hand	d ₁	d ₂	l ₁	l ₂	d ₃	d ₄	d ₅	h ₁	h ₂	h ₃	l ₃	A/F	Weight g
65542.W0105	Right	6.35	M 5	23.0	28	7.9	11.1	4.35	11.1	11.9	28.6	11.1	8	17
65542.W0106	Right	7.9	M 6	24.6	30	9.4	13.0	4.95	12.6	12.6	33.4	13.0	10	25
65542.W0108	Right	8.6	M 8	31.7	40	11.1	16.0	5.8	15.2	15.2	40.6	14.3	11	48
65542.W0110	Right	10.7	M10	39.7	49	14.1	19.0	6.85	19.8	19.8	51.4	27.0	13	78

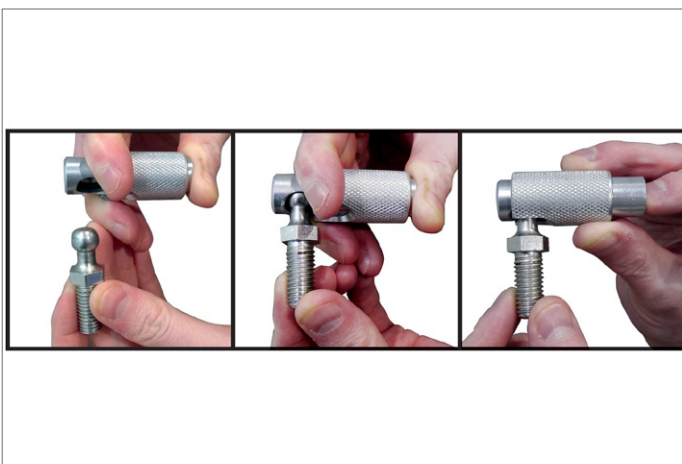



64500

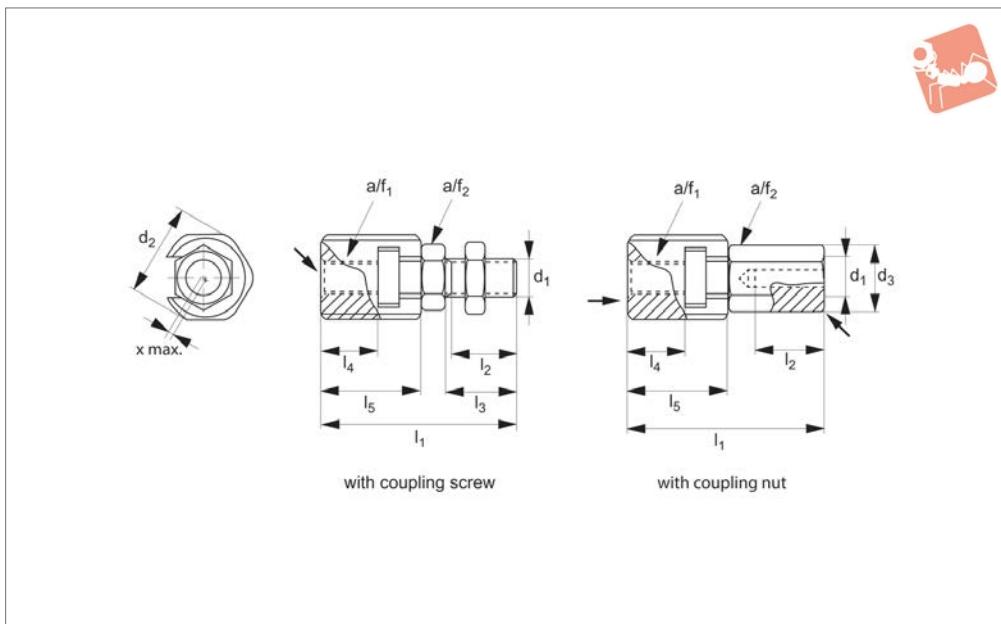

Material

Body: steel, heat-treated, phosphated.
Lock nut: steel, blackened (ISO 4035/8675).

Technical Notes

For quick coupling/uncoupling of components within a linear movement application, with the additional advantage

of compensating for radial off-set between the components. In built adjustment feature of the quick plug coupling means manual adjustment of the coupled units is unnecessary. Coupling via means of a t-slot channel within the coupling nut.

Tips

Can be linked to pneumatic and hydraulic

lifting cylinders in many different applications.

Important note: suitable for linear movement applications, does not transmit any torque.

Order No.	Coupling Type	d ₁	d ₂	d ₃	l ₁ ≈	l ₂ min.	l ₃	l ₄ min.	l ₅	Tensile & compression load kN max.	A/F ₁	A/F ₂	Axial offset x max.	Weight g
64500.W0006	Screw	M_6	21,0		37,5	11,0	14	9,0	18,0	2,5	19	10	0,6	44
64500.W0008	Screw	M_8	26,0		45,0	13,5	17	11,5	22,5	4,5	24	13	0,7	86
64500.W0010	Screw	M10	30,0		56,2	16,0	20	16,0	29,0	6,5	27	17	0,7	147
64500.W0012	Screw	M12	32,5		66,7	21,0	25	17,0	34,0	10,0	30	19	0,8	208
64500.W0016	Screw	M16	39,0		83,0	25,0	30	23,0	42,0	18,0	36	24	1,0	383
64500.W0020	Screw	M20	44,0		93,5	29,0	35	23,5	45,5	30,0	41	30	1,0	571
64500.W0030	Screw	M10 x 1,25	30,0		56,2	16,0	20	16,0	29,0	6,5	27	17	0,7	147
64500.W0032	Screw	M12 x 1,25	32,5		66,7	21,0	25	17,0	34,0	10,0	30	19	0,8	207
64500.W0036	Screw	M16 x 1,50	39,0		83,0	25,0	30	23,0	42,0	18,0	36	24	1,0	384
64500.W0040	Screw	M20 x 1,50	44,0		93,5	29,0	35	23,5	45,5	30,0	41	30	1,0	576
64500.W0056	Nut	M_6	21,0	11,0	37,5	11,0		9,0	18,0	2,5	19	10	0,6	47
64500.W0058	Nut	M_8	26,0	14,4	45,0	13,5		11,5	22,5	4,0	24	13	0,7	91
64500.W0060	Nut	M10	30,0	19,0	56,2	15,0		16,0	29,0	6,5	27	17	0,7	160
64500.W0062	Nut	M12	32,5	21,2	66,7	17,5		17,0	34,0	10,0	30	19	0,8	223
64500.W0066	Nut	M16	39,0	27,0	83,0	22,0		23,0	42,0	18,0	36	24	1,0	401
64500.W0070	Nut	M20	44,0	34,0	93,5	25,0		23,5	45,5	30,0	41	30	1,0	606
64500.W0080	Nut	M10 x 1,25	30,0	19,0	56,2	15,0		16,0	29,0	6,5	27	17	0,7	159
64500.W0082	Nut	M12 x 1,25	32,5	21,2	66,7	17,5		17,0	34,0	10,0	30	19	0,8	221
64500.W0086	Nut	M16 x 1,50	39,0	27,0	83,0	22,0		23,0	42,0	18,0	36	24	1,0	400
64500.W0090	Nut	M20 x 1,50	44,0	34,0	93,5	25,0		23,5	45,5	30,0	41	30	1,0	601



Quick Plug Couplings with radial offset compensation

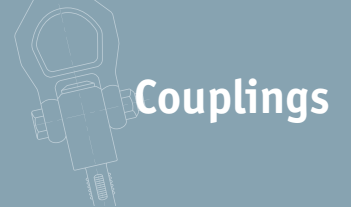

Couplings

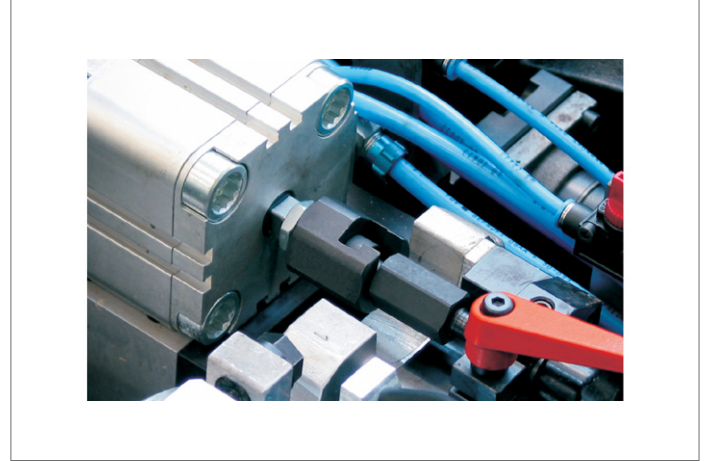
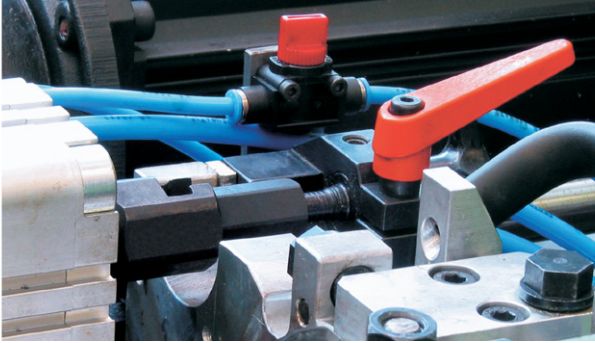

COUPLINGS



64600

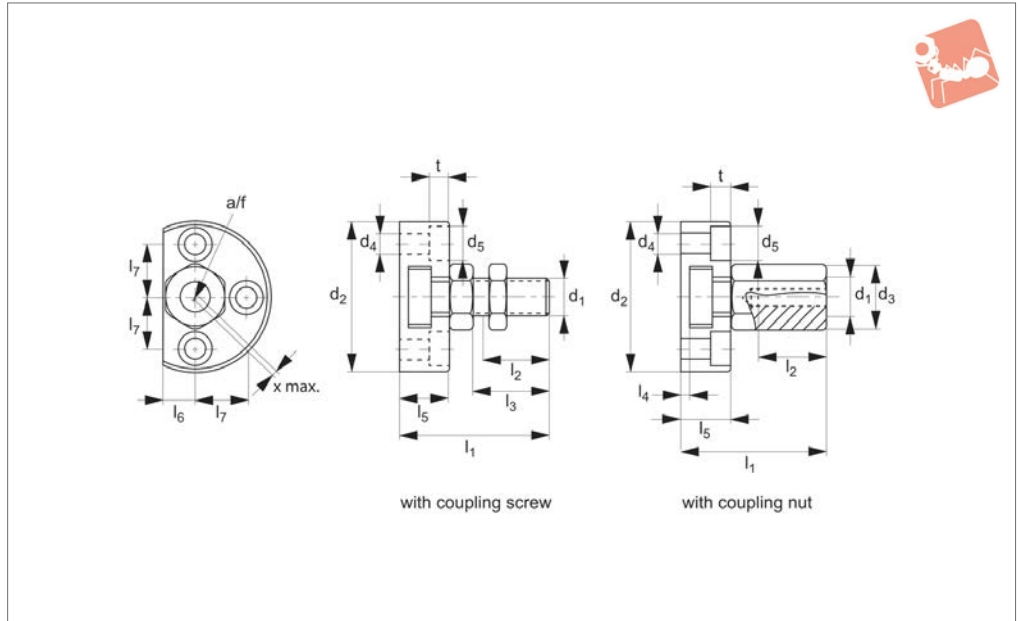

Material

Body: steel, heat-treated, tempered, phosphated.

Lock nut: steel, blackened (ISO 4035/8675).

Technical Notes

For quick coupling/uncoupling of components within a linear movement application, with the additional advantage

of compensating for radial off-set between the components. In built adjustment feature of the quick plug coupling means manual adjustment of the coupled units is unnecessary. Coupling via means of a t-slot channel within the coupling nut.

*kN max is the maximum tensile and compression load.

Tips

Ideal quick coupler where space is limited. Can be linked to pneumatic and hydraulic lifting cylinders in many different applications.

Important note: suitable for linear movement applications, does not transmit any torque.

Order No.	Coupling Type	d ₁	d ₂	d ₃	d ₄	d ₅	Weight g
64600.W0206	Screw	M_6	42	-	5.5	10	75
64600.W0208	Screw	M_8	48	-	6.6	11	116
64600.W0210	Screw	M10	50	-	6.6	11	175
64600.W0212	Screw	M12	55	-	6.6	11	281
64600.W0216	Screw	M16	65	-	9.0	15	458
64600.W0220	Screw	M20	80	-	11.0	18	817
64600.W0230	Screw	M10x1,25	50	-	6.6	11	176
64600.W0232	Screw	M12x1,25	55	-	6.6	11	280
64600.W0236	Screw	M16x1,50	65	-	9.0	15	454
64600.W0240	Screw	M20x1,50	80	-	11.0	18	850
64600.W0256	Nut	M_6	42	11.0	5.5	10	77
64600.W0258	Nut	M_8	48	14.4	6.6	11	123
64600.W0260	Nut	M10	50	19.0	6.6	11	187
64600.W0262	Nut	M12	55	21.2	6.6	11	295
64600.W0266	Nut	M16	65	27.0	9.0	15	472
64600.W0270	Nut	M20	80	34.0	11.0	18	849
64600.W0280	Nut	M10x1,25	50	19.0	6.6	11	187
64600.W0282	Nut	M12x1,25	55	21.2	6.6	11	298
64600.W0286	Nut	M16x1,50	65	27.0	9.0	15	477
64600.W0290	Nut	M20x1,50	80	34.0	11.0	18	852

Order No.	l ₁ ≈	l ₂ min.	l ₃	l ₄	l ₅	l ₆	l ₇	A/F	t	Axial offset x max.	kN kN max.
64600.W0206	30.5	11.0	14	3.0	11.0	7.0	14.0	10	5.4	0.6	2.5
64600.W0208	35.5	13.5	17	3.0	13.0	8.0	16.0	13	6.4	0.7	4.5
64600.W0210	43.2	16.0	20	4.2	16.0	9.0	17.0	17	6.4	0.7	6.5



Quick Plug Couplings

with radial offset compensation and screwed flange

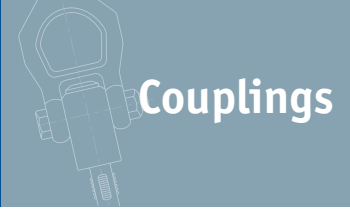

Order No.	l_1 ≈	l_2 min.	l_3	l_4	l_5	l_6	l_7	A/F	t	Axial offset x max.	kN kN max.
64600.W0212	53.2	21.0	25	4.2	20.5	10.0	19.0	19	6.4	0.8	10.0
64600.W0216	64.0	25.0	30	5.0	23.0	12.5	22.5	24	8.5	1.0	18.0
64600.W0220	74.0	29.0	35	5.0	26.0	17.0	28.0	30	10.4	1.0	30.0
64600.W0230	43.2	16.0	20	4.2	16.0	9.0	17.0	17	6.4	0.7	6.5
64600.W0232	53.2	21.0	25	4.2	20.5	10.0	19.0	19	6.4	0.8	10.0
64600.W0236	64.0	25.0	30	5.0	23.0	12.5	22.5	24	8.5	1.0	18.0
64600.W0240	74.0	29.0	35	5.0	26.0	17.0	28.0	30	10.0	1.0	30.0
64600.W0256	30.5	11.0	-	3.0	11.0	7.0	14.0	10	5.4	0.6	2.5
64600.W0258	35.5	13.5	-	3.0	13.0	8.0	16.0	13	6.4	0.7	4.5
64600.W0260	43.2	15.0	-	4.2	16.0	9.0	17.0	17	6.4	0.7	6.5
64600.W0262	53.2	17.5	-	4.2	20.5	10.0	19.0	19	6.4	0.8	10.0
64600.W0266	64.0	22.0	-	5.0	23.0	12.5	22.5	24	8.5	1.0	18.0
64600.W0270	74.0	25.0	-	5.0	26.0	17.0	28.0	30	10.0	1.0	30.0
64600.W0280	43.2	15.0	-	4.2	16.0	9.0	17.0	17	6.4	0.7	6.5
64600.W0282	53.2	17.5	-	4.2	20.5	10.0	19.0	19	6.4	0.8	10.0
64600.W0286	64.0	22.0	-	5.0	23.0	12.5	22.5	24	8.5	1.0	18.0
64600.W0290	74.0	25.0	-	5.0	26.0	17.0	28.0	30	10.0	1.0	30.0

COUPLINGS

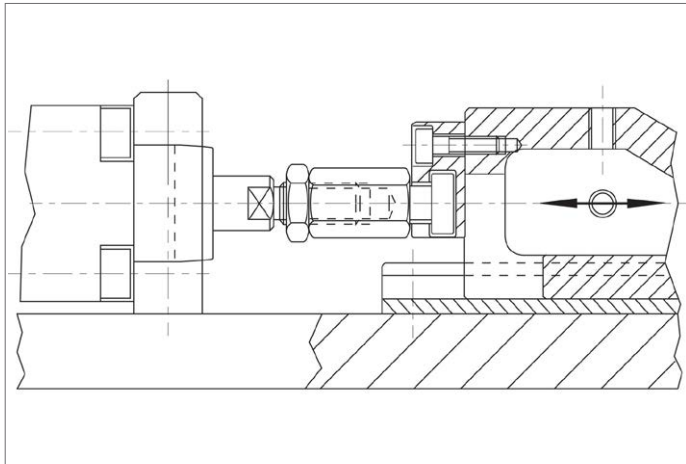



64700

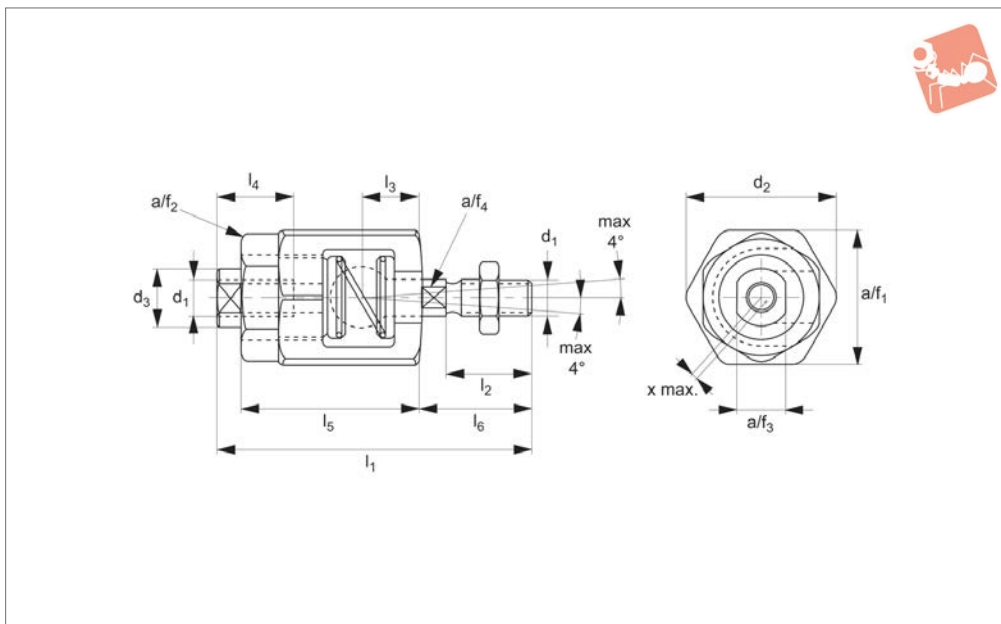

Material

Body: steel, heat-treated, tempered, phosphated.

Nut: steel, heat-treated, phosphated.

Spring: stainless steel.

Coupling part: steel, heat-treated, nitrided, blackened.

Lock nut: steel, blackened (ISO 4035/8675).

Technical Notes

Compensates for both radial off-set and

angular off-set between the components, making it ideal for applications with non-aligned linear components. Inbuilt adjustment feature of the quick plug coupling means manual adjustment of the coupled units is unnecessary. Coupling via means of a t-slot channel within the coupling nut.

Tips

Solid and compact design, no loose elements. Can be linked to pneumatic and hydraulic lifting cylinders in many different

applications.

Important note: suitable for linear movement applications, does not transmit any torque.

Order No.	d ₁	d ₂	d ₃	l ₁ ≈	l ₂	l ₃	Weight g
64700.W0406	M 6	24.5	9.6	52	14	9.5	75
64700.W0408	M 8	30.0	15.0	63	18	11.5	137
64700.W0410	M10	44.0	21.0	81	22	16.0	401
64700.W0412	M12	44.0	21.0	85	26	16.0	405
64700.W0416	M16	60.0	32.0	121	34	26.0	1127
64700.W0420	M20	60.0	32.0	129	42	26.0	1152
64700.W0430	M10x1,25	44.0	21.0	81	22	16.0	403
64700.W0432	M12x1,25	44.0	21.0	85	26	16.0	406
64700.W0436	M16x1,50	60.0	32.0	121	34	26.0	1128
64700.W0440	M20x1,50	60.0	32.0	129	42	26.0	1155

Order No.	l ₄ min.	l ₅	l ₆	Radial offset compensation max.	Tensile load kN max.	A/F ₁	A/F ₂	A/F ₃	A/F ₄
64700.W0406	13	29	18.5	0.6	2.5	22	19	8	5
64700.W0408	16	33	23.5	0.6	4.5	27	24	13	7
64700.W0410	24	43	30.5	0.7	6.5	41	36	18	12
64700.W0412	24	43	34.5	0.7	10.0	41	36	18	12
64700.W0416	34	62	45.0	1.0	18.0	55	46	27	18
64700.W0420	34	62	53.0	1.0	30.0	55	46	27	18
64700.W0430	24	43	30.5	0.7	6.5	41	36	18	12
64700.W0432	24	43	34.5	0.7	10.0	41	36	18	12
64700.W0436	34	62	45.0	1.0	18.0	55	46	27	18
64700.W0440	34	62	53.0	1.0	30.0	55	46	27	18

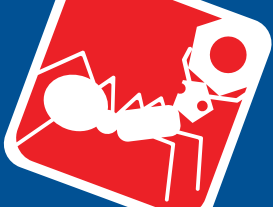

Quick Plug Couplings with angular radial offset compensation

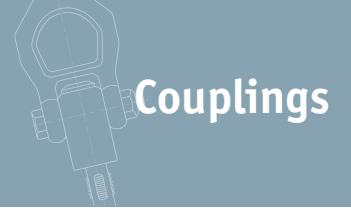

Couplings

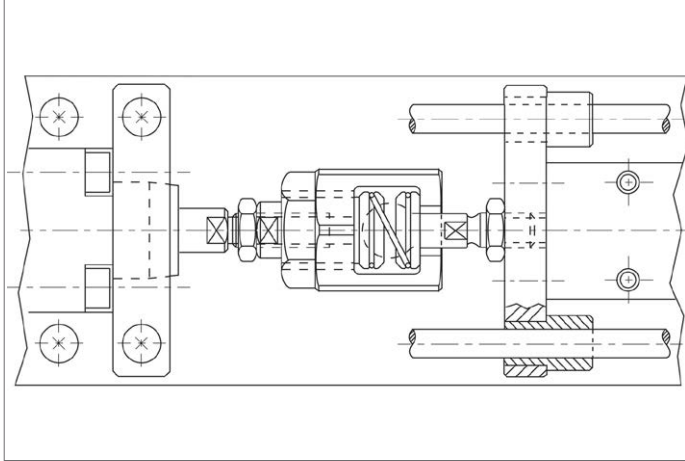

COUPLINGS



64775

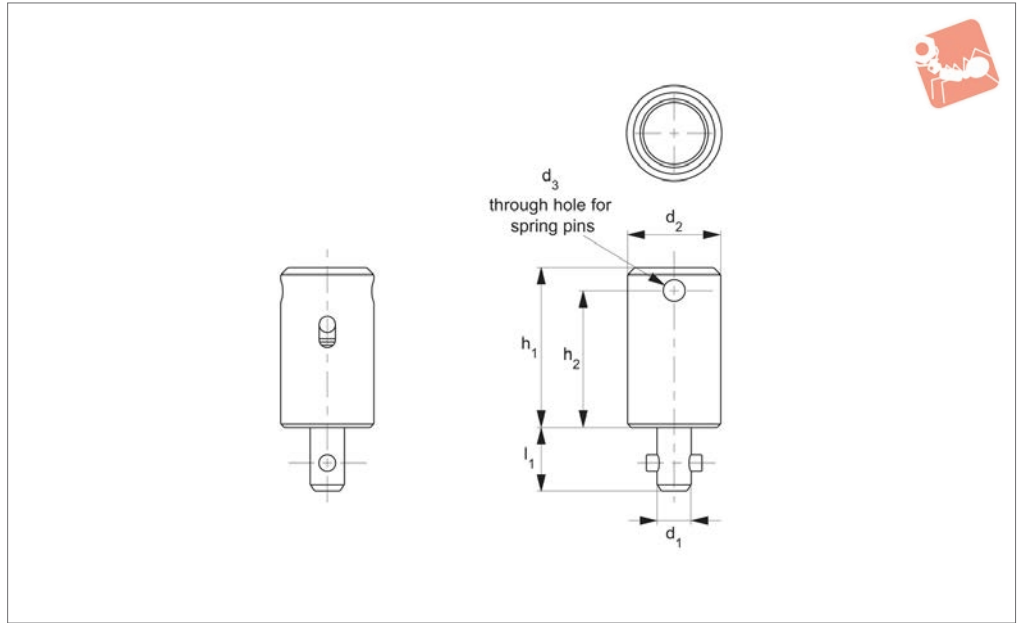

Material

Body: steel S45C, nickel plated.

Pin and Spring: stainless steel, SUS304

Technical Notes

For quick coupling/uncoupling of components within a linear movement application. Coupling via means of a 90° turn of coupling into the cam locking receiver. Please order receivers separately, see part nos. 64780 and 64782. Temperature resistant to 200 °C

Tips

Can be linked to pneumatic and hydraulic

lifting cylinders in many different applications.

Important Notes

Suitable only for linear movement applications, does not transmit any torque.

Actuation:

- Following installation dimensions for both coupling and receiver in introductory pages.

- Once coupling and receiver are correctly installed, align male coupling to female receiver, paying attention to correctly

align pins on the coupling's shaft to holes in receiver.

- Engage coupling and receiver, to lock turn shaft or block 90 degrees to clamp.

- When properly locked an audible „click“ is heard.

- When properly installed, repeatability of upto +/- 0.08mm is achievable.

- To release, reverse steps described above.

Order No.	d_1 -0.04 -0.08	d_2 -0.04 -0.08	d_3	h_1	h_2	l_1	Shear strength N	Tensile strength N	Clamping force N max.	Weight g
64775.W0514	5	14	3	23.5	20	9.5	1800	1200	30	25



Receiver - Shaft Mount - Cam Locking

for Quick Plug Coupling no. 64775

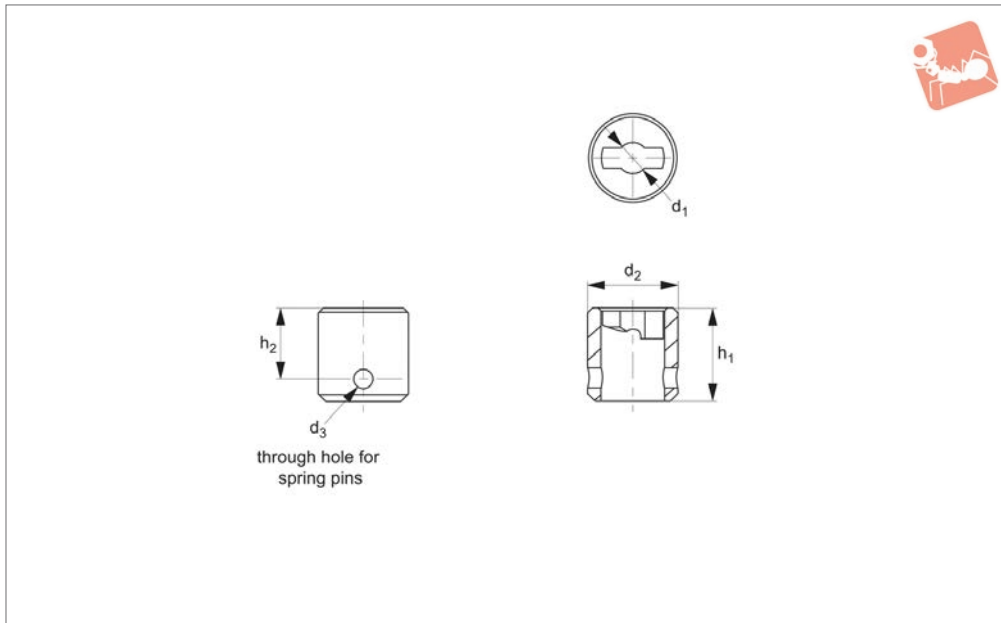
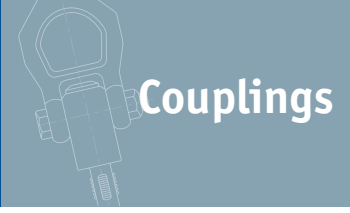

64780

COUPLINGS

Material

Body: tempered steel SCM440, nickel plated.

Technical Notes

Receiver for use with quick plug coupling,

cam locking no. 64775. Shaft mount version suited to installation on shafts; such as the end of pneumatic or hydraulic cylinders.

Temperature resistant to 200° C

Important Notes

Suitable only for linear movement applications, does not transmit any torque.

Order No.	d_1 +0.08 +0.04	d_2 tol. h9	d_3	h_1	h_2	Weight g
64780.W0514	5	14	3	14.5	11	10



Operating Principle

When the male quick plug coupling is fully inserted into the receiver and actuated, the internal spring is compressed to clamp the shaft.

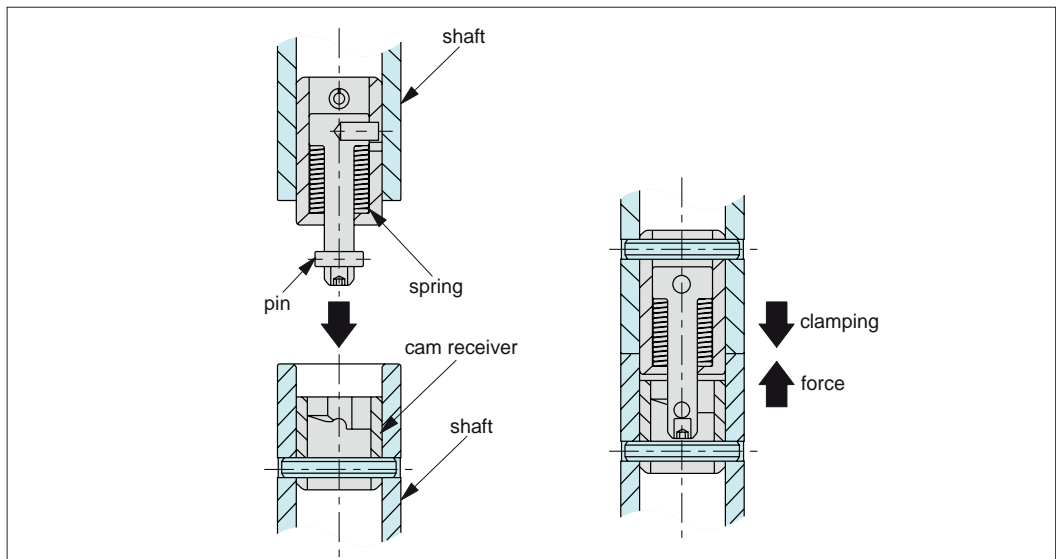

Operating Instructions

- 1 Insert the shaft into the keyway of cam receiver.
- 2 Rotate the shaft block 90° to clamp the element. An audible click can be heard when clamped. For unclamping, reverse these steps.

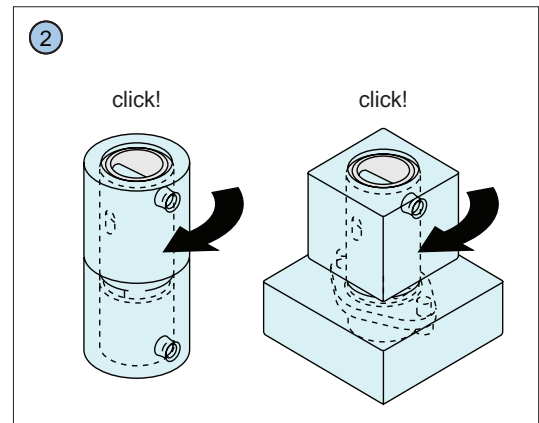
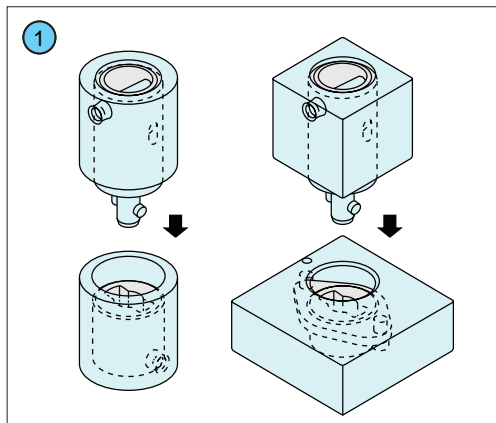

Operating Dimensions

How to mount shaft coupling clamp

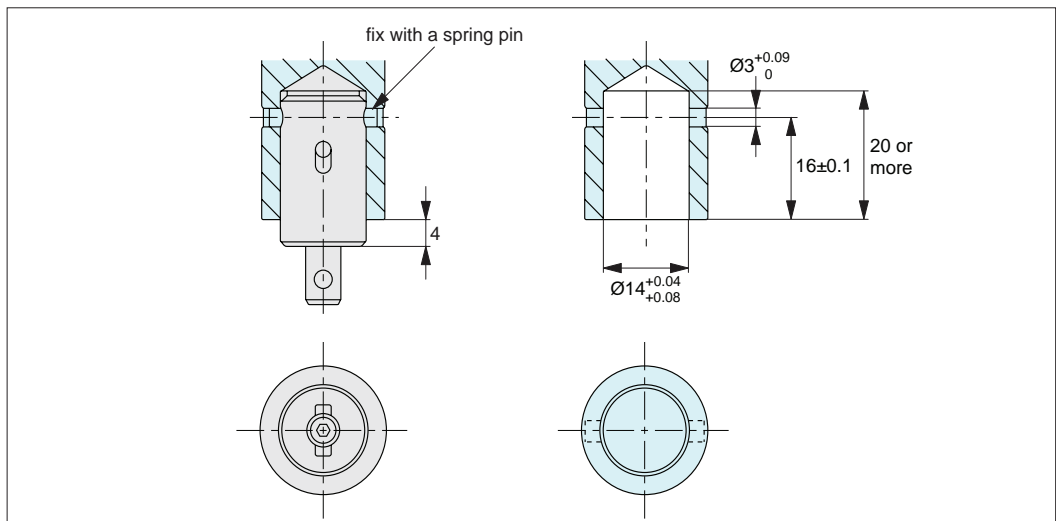

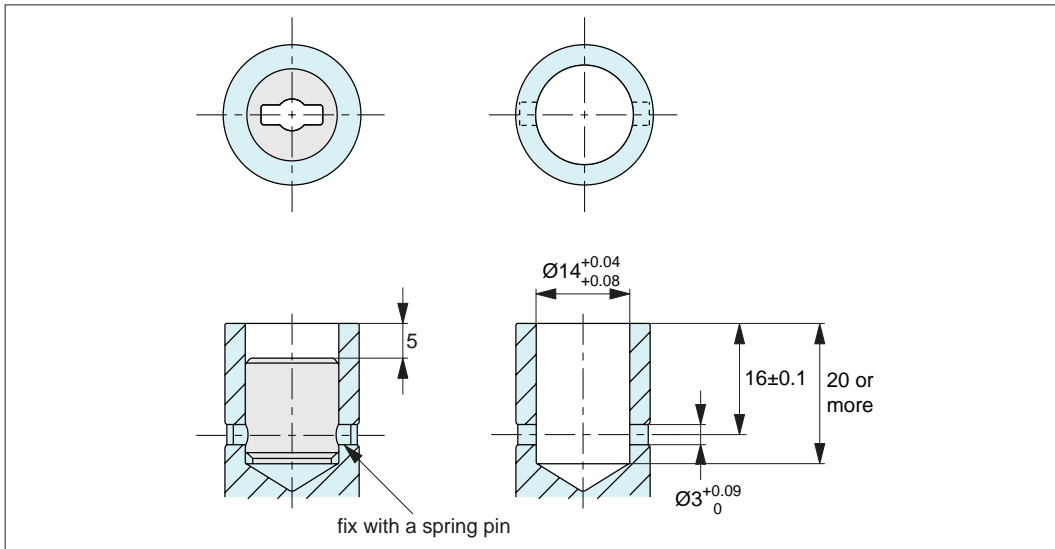

How to mount receiver (shaft mount)

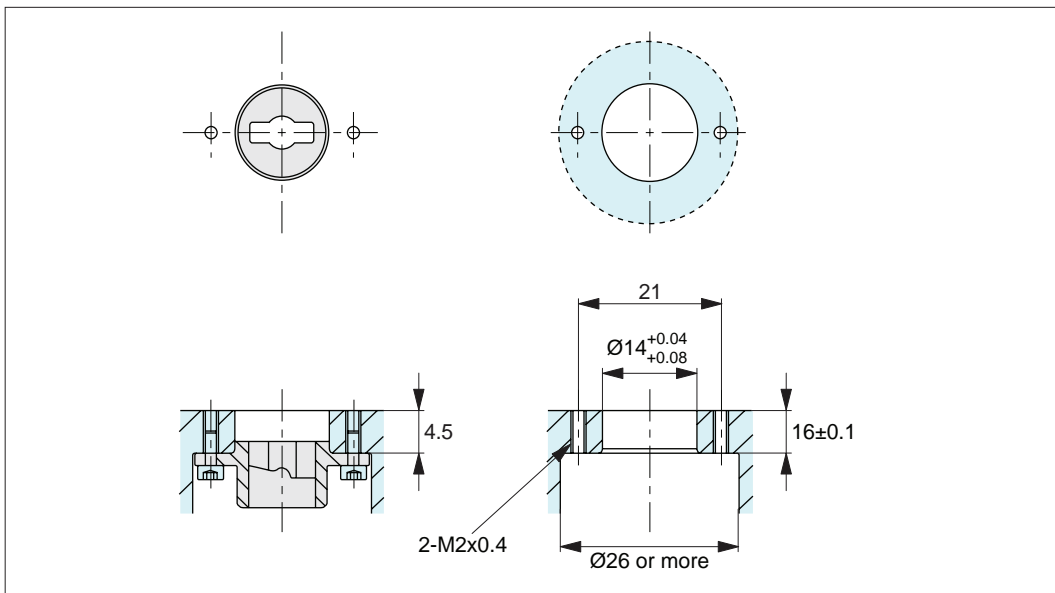

How to mount receiver (plate mount)

Repeatability

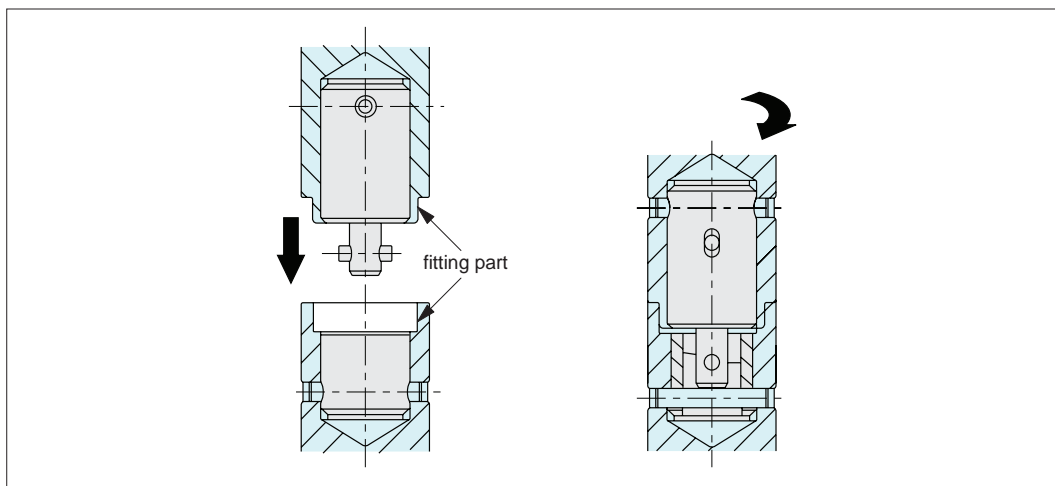

Prepare male and female fittings for highly accurate locating. Repeatability of ± 0.08 is achievable.



Applications

Changes of thrust pads

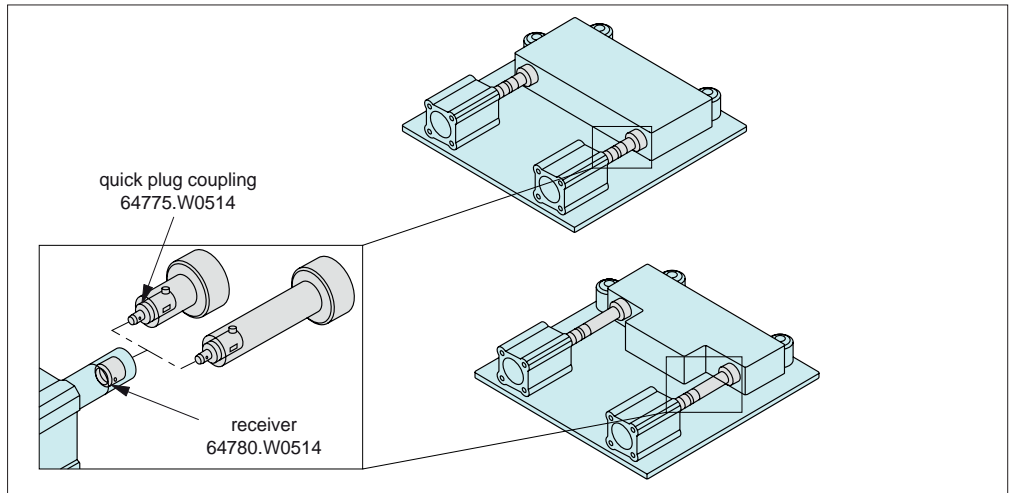

Changes of riser

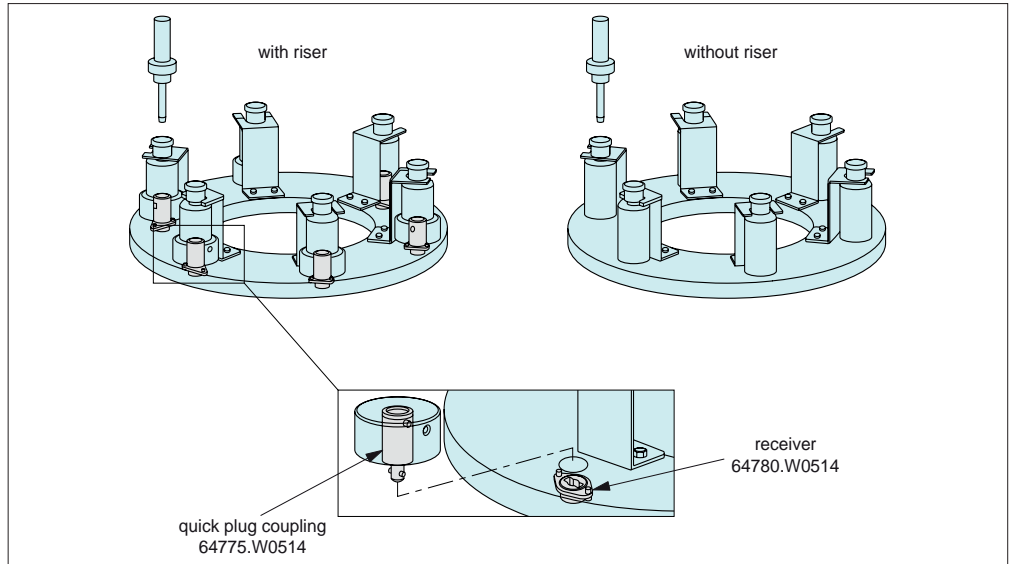

Notes

Pay attention to the direction of holes for spring pins.

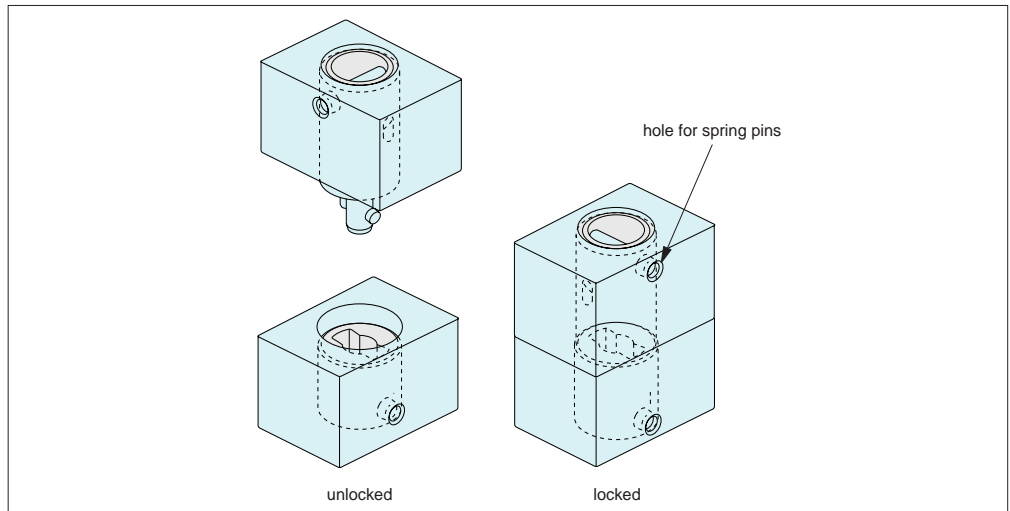

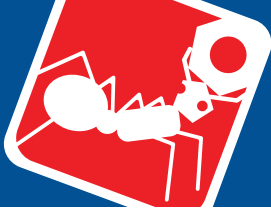

Receiver - Plate Mount - Cam Locking for Quick Plug Coupling no. 64775

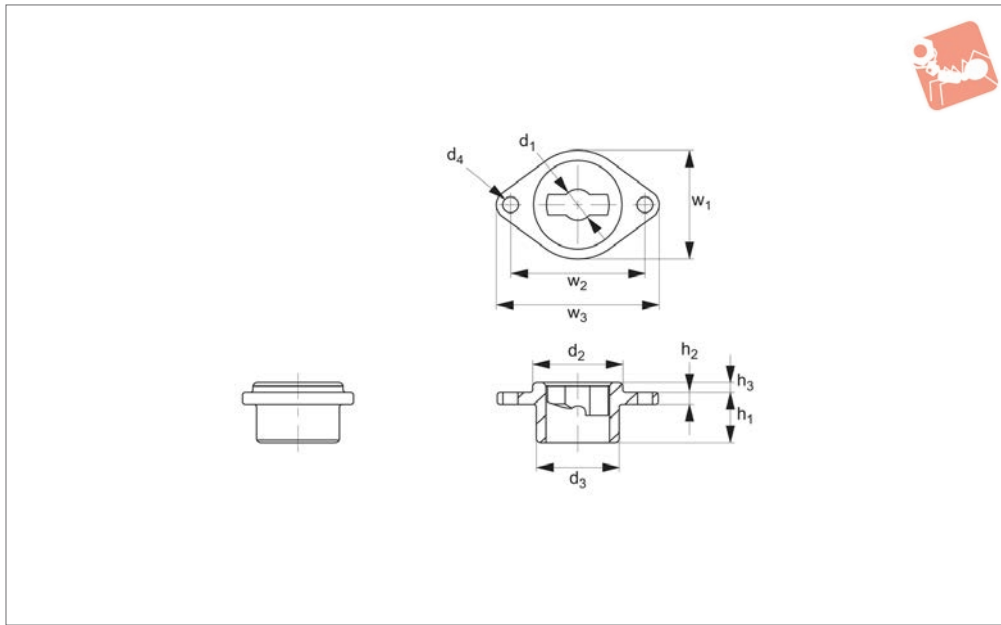
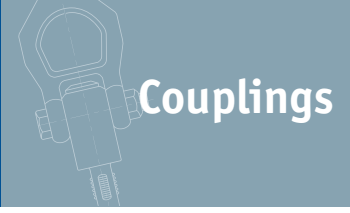

64782

COUPLINGS

Material

Body: tempered steel SCM440, nickel plated.

Technical Notes

Receiver for use with quick plug coupling,

cam locking no. 64775. Plate mount version suited to installation in thin walled parts, and sub-flush to the mounting surface.

Temperature resistant to 200° C

Suitable only for linear movement applications, does not transmit any torque.

Order No.	d_1 +0.08 +0.04	d_2 tol. h9	d_3	d_4	h_1	h_2	h_3	w_1	w_2	w_3	Weight g
64782.W0514	5	14	13	2.4	8	2	1.5	17	21	25	8