

36560

CLAMP CLEATS

Material

Stainless steel (A4, AISI316, DIN 1.4401), with nylon insert.

Supplied with A2 (AISI303) stainless steel screw (screws not supplied with P1092.019, .020, or .026).

Technical Notes

Quick release, faster clamping and self-locking.

Tips

Bolt circle: use the larger of the following two bolt circles:

add 6,86 to max. flange diameter or add 10,16 to max. groove base diameter.

Order No.	h_1 $\pm 6,08$	d_1	h_2 $\pm 0,08$	h_3	h_4	l_1 $+0 -0.8$	w_1	w_2 $+0 -0.15$
36560.W0006	0.79	M3	1.02	1.80	1.73	8.0	9.90	3.18
36560.W0007	1.57	M3	1.02	2.59	1.73	8.0	9.90	3.18
36560.W0008	1.58	M3	1.27	2.84	1.73	10.0	9.90	3.18
36560.W0009	1.57	M3	1.60	3.18	1.73	10.0	9.90	3.18
36560.W0010	1.98	M3	1.60	3.58	1.73	10.0	9.90	3.18
36560.W0011	2.36	M3	1.02	3.38	1.73	10.0	9.90	3.18
36560.W0012	2.36	M3	1.27	3.63	1.73	10.0	9.90	3.18
36560.W0013	2.36	M3	1.60	3.96	1.73	10.0	9.90	3.18
36560.W0014	3.18	M3	1.27	4.45	1.73	10.0	9.90	3.18
36560.W0015	3.96	M3	1.02	4.98	1.73	10.0	9.90	3.18
36560.W0016	5.72	M3	1.60	7.32	1.73	12.0	9.90	3.18
36560.W0017	6.35	M3	1.60	7.92	1.73	16.0	9.90	3.18

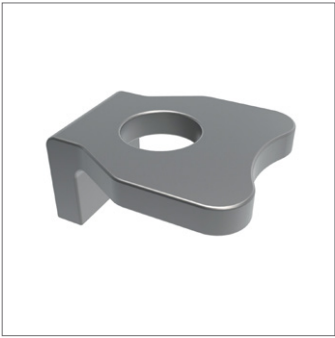

36580

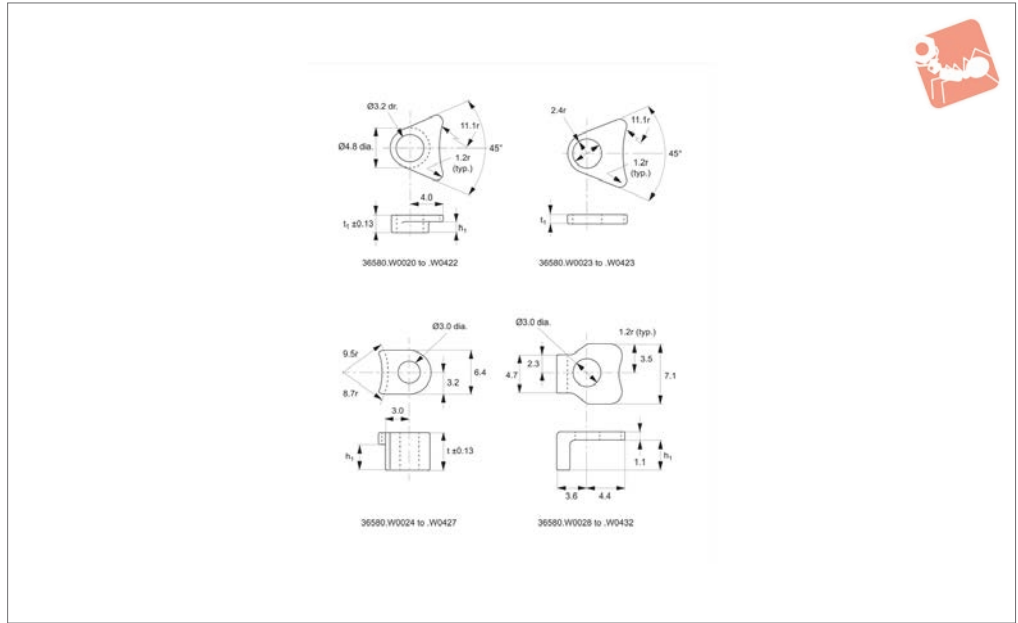

Material

Stainless steel DIN 1,4305 (AISI 303) or aluminium 2024.

Technical Notes

Quick release, faster clamping and self-

locking.

10,16 to max. groove base diameter.

Tips

Bolt circle: use the larger of the following two bolt circles:
add 6,86 to max. flange diameter OR add

Order No.	Type	Material	h_1	t_1
36580.W0020	A	Stainless	1.2	2.36
36580.W0021	A	Stainless	1.2	2.36
36580.W0022	A	Stainless	2.8	3.96
36580.W0023	B	Stainless	2.8	3.96
36580.W0024	C	Stainless	5.3	6.91
36580.W0025	C	Stainless	5.3	6.91
36580.W0026	C	Stainless	-	1.02
36580.W0027	C	Stainless	-	1.02
36580.W0028	D	Stainless	0.5	1.65
36580.W0029	D	Stainless	0.5	1.65
36580.W0030	D	Stainless	1.3	2.41
36580.W0031	D	Stainless	1.3	2.41
36580.W0032	D	Stainless	2.9	4.06
36580.W0420	A	Aluminium	2.9	4.06
36580.W0421	A	Aluminium	4.5	5.59
36580.W0422	A	Aluminium	4.5	5.59
36580.W0423	B	Aluminium	Flat	-
36580.W0424	C	Aluminium	1.2	-
36580.W0425	C	Aluminium	2.0	-
36580.W0426	C	Aluminium	2.8	-
36580.W0427	C	Aluminium	3.6	-

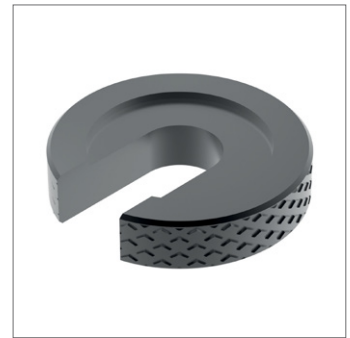
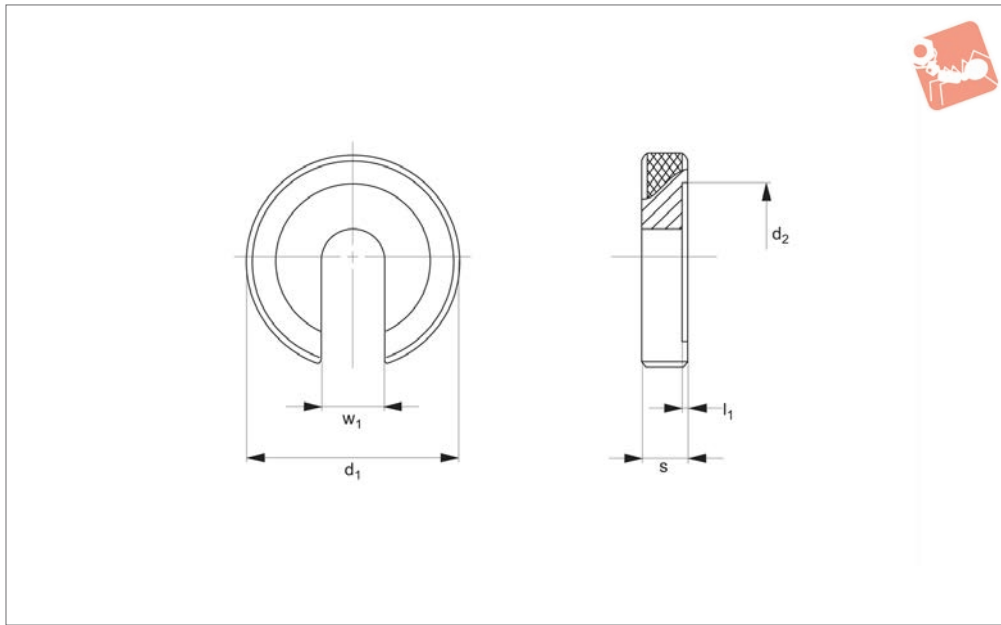

36600

CLAMP CLEATS

Material

Heat-treated steel, blackened, tempered.

Technical Notes

Produced to DIN 6372.

Order No.	d_1	w_1	l_1	d_2	s	Weight g
36600.W0012	40	13	1.8	30	9	57
36600.W0016	56	17	1.8	37	12	164