

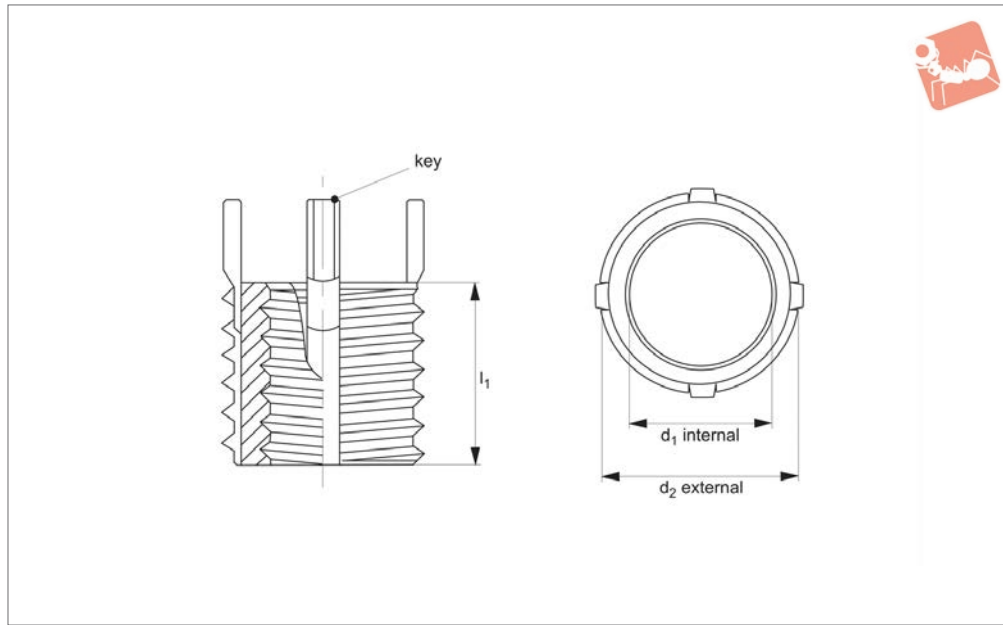

Threaded Insert - Metric - Inch heavy duty - carbon steel



Threaded Inserts



22010

THREADED INSERTS

Material

Inserts: carbon steel (C1215) or equivalent. Zinc phosphate.

Keys: stainless steel (302 CRES) or equivalent. Passivated.

Technical Notes

General tolerances:

± 0,010" unless specified.

Tap drill hole tolerances:

0,234 to 0,500 = +0,004/-0,001".

0,500 and over = +0,005/-0,001".

Tips

Order installation tool separately, as identified by „Inst. tool ref.“ in table.

Important Notes

Four locking keys on internal threads M8 and over. Two locking keys on internal

threads smaller than M8.

Installation (Inst.) drill size, countersink, thread tap and thread depth as specified in table.

Removal drill size and drill depth as specified in table.

Internal thread in metric. External thread in inches.

Order No.	Int. d ₁ tol. 6H	Int. thread type d ₁	Ext. d ₂ tol. 2A	Ext. thread type d ₂	l ₁	Inst. tool ref. 22064	Inst. tap drill size	Inst. c'sink dia. +0.010 - 0.000	Inst. thread tap tol. 2B	Inst. thread depth min.	Removal drill size	Removal drill depth
22010.W0430	M 6x1,00	Coarse	3/8"-16	UNC	0,31	.W0430	21/64"	0,38	3/8"-16	0,37	9/32"	1/8"
22010.W0440	M 8x1,25	Coarse	1/2"-13	UNC	0,43	.W0440	29/64"	0,51	1/2"-13	0,50	13/32"	3/16"
22010.W0450	M10x1,50	Coarse	5/8"-11	UNC	0,50	.W0450	37/64"	0,63	5/8"-11	0,56	17/32"	3/16"
22010.W0470	M12x1,75	Coarse	3/4"-16	UNF	0,62	.W0470	45/64"	0,76	3/4"-16	0,68	21/32"	3/16"
22010.W0480	M14x2,00	Coarse	7/8"-14	UNF	0,81	.W0480	53/64"	0,88	7/8"-14	0,94	25/32"	5/16"
22010.W0490	M16x2,00	Coarse	1"-12	UNF	0,87	.W0490	15/16"	1,02	1"-12	1,00	27/32"	5/16"



22012

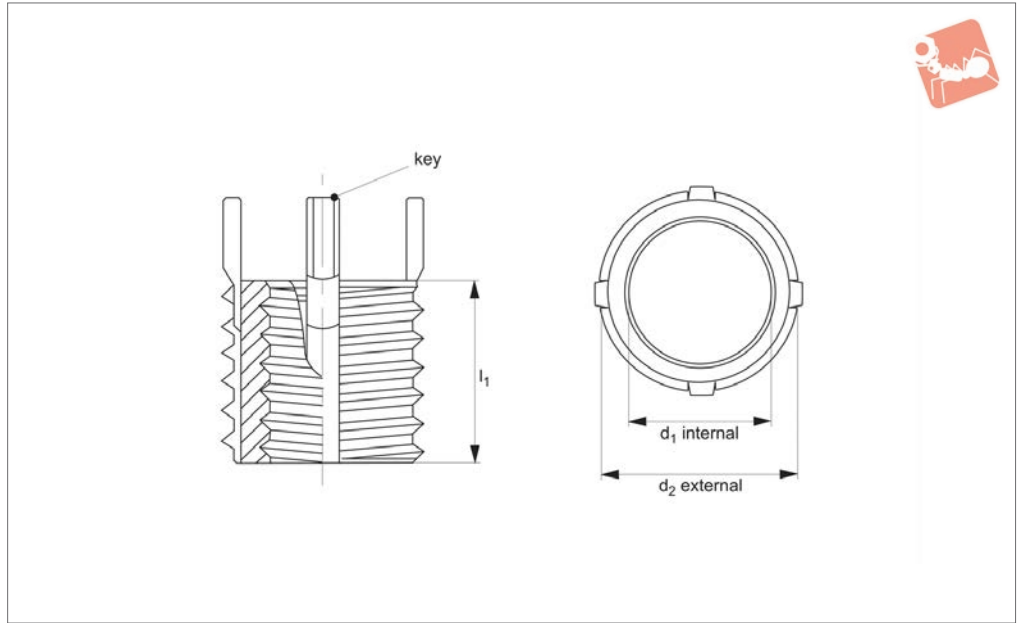

Material

Inserts: stainless steel (AISI 303) or equivalent. Passivated.

Keys: stainless steel (302 CRES) or equivalent. Passivated.

Technical Notes

General tolerances:

±0,010" unless specified.

Tap drill hole tolerances:

0,234 to 0,500 = +0,004/-0,001"
0,500 and over = +0,005/-0,001"

Tips

Order installation tool separately, as identified by „Inst. Tool ref.“ in table.

Important Notes

Four locking keys on internal threads M8 and over. Two locking keys on internal

threads smaller than M8.

Installation (Inst.) drill size, countersink, thread tap and thread depth as specified in table.

Removal drill size and drill depth as specified in table.

Internal thread in metric. External thread in inches.

Order No.	Int. d ₁ tol. 6H	Int. thread type d ₁	Ext. d ₂ tol. 2A	Ext. thread type d ₂	l ₁	Inst. tool ref. 22064	Inst. tap drill size	Inst. c'sink dia. +0.010 - 0.000	Inst. thread tap tol. 2B	Inst. thread depth min.	Removal drill size	Removal drill depth
22012.W5430	M 6x1,00	Coarse	3/8"-16	UNC	0,3	.W0430	21/64"	0,38	3/8"-16	0,37	9/32"	1/8"
22012.W5440	M 8x1,25	Coarse	1/2"-13	UNC	0,4	.W0440	29/64"	0,51	1/2"-13	0,50	13/32"	3/16"
22012.W5450	M10x1,50	Coarse	5/8"-11	UNC	0,5	.W0450	37/64"	0,63	5/8"-11	0,56	17/32"	3/16"
22012.W5470	M12x1,75	Coarse	3/4"-16	UNF	0,6	.W0470	45/64"	0,76	3/4"-16	0,68	21/32"	3/16"
22012.W5480	M14x2,00	Coarse	7/8"-14	UNF	0,8	.W0480	53/64"	0,88	7/8"-14	0,94	25/32"	5/16"
22012.W5490	M16x2,00	Coarse	1"-12	UNF	0,9	.W0490	15/16"	1,02	1"-12	1,00	27/32"	5/16"

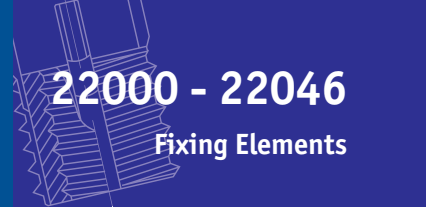
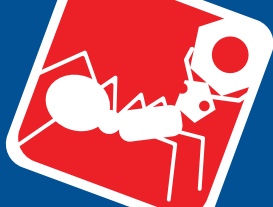

THREADED INSERTS

Threaded inserts are used to quickly repair stripped, damaged or worn out threads with new stronger threads, or are used in original equipment to guarantee stronger thread connections.

Wixroyd inserts are easy to install and remove, without the need for special drills, taps or pre-winder tools. The 'locking keys' on threaded inserts are easily driven down into the thread of the surrounding base material – locking the insert securely in place.



Carbon steel inserts



Stainless steel inserts



Solid inserts

Key Features

- Solid, one-piece construction providing high pull-out strengths.
- Locking "keys" provide a positive mechanical lock against rotation of the insert.
- Easy installation and removal.
- Installation with standard drills and taps.
- No pre-winder tools required.
- No tangs to break off and account for in the assembly.
- For use in a wide variety of materials.
- Both metric and imperial sizes available in coarse and fine pitches.

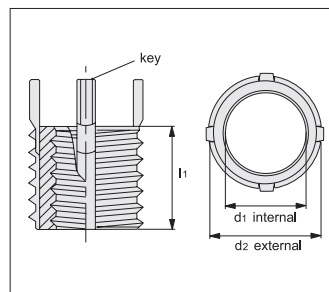

Installation and Removal

- 1 Select desired threaded insert, and from the product data table identify the installation drill and tap sizes (note the drill is slightly oversized deliberately). Drill with standard tap drill as per product data table, and countersink with standard 82-100° countersink.
- 2 Tap new threads with standard tap – as specified in product data table.
- 3 Screw in the insert until it is 0.25 to 0.75mm (0.010 to 0.030 inch) below the surface.
- 4 Drive locking keys down with several hammer taps on the installation tool – see product data table for correct tool.
- 5 Insert is installed.



Installation

Wixroyd threaded inserts, can be removed (if required) without damage to the surrounding material.

- 1 Refer to product data tables to identify the drill size and drill depth required for removal. Drill out the material between the insert keys and the internal thread to specified depth.

- 2 Bend the locking keys inward and break off.
- 3 Remove the old insert using a screw extractor.
- 4 Install a replacement insert into the original tapped hole.

Removal



Stainless Steel



22000 - Thinwall - Metric
Use installation tool no. 22060.



22002 - Heavy Duty - Metric.
Use installation tool no. 22062.



22012 - Heavy Duty - Metric - Inch.
Use installation tool no. 22064.



22020, 22022, 22024 - Inch - Thinwall - Heavy Duty - Extra Heavy Duty.
Use installation tool no. 22054-58.

Carbon Steel



22004 - Thinwall - Metric
Use installation tool no. 22060.



22006 - Heavy Duty - Metric
Use installation tool no. 22062.



22010 - Heavy Duty - Metric - Inch.
Use installation tool no. 22064.



22030 - 22034 - Inch - Thinwall - Heavy Duty - Extra Heavy Duty
Use installation tool no. 22054, 20058.

Solid



22040 - Metric - Carbon
Use installation tool no. 22052.



22042 - Metric - Stainless Steel
Use installation tool no. 22052.



22044 - Inch - Carbon
Use installation tool no. 22050.



22046 - Inch - Stainless Steel
Use installation tool no. 22050.

Installation Tools



22050 for 22044 & 22046



22052 for 22040 & 22042



22054, 22058 for 22020, 22024, 22030, 22034,



22060 for 22000 & 22004



22062 for 22002 & 22006



22064 for 22010 & 22012



Installation Tool - Inch - Heavy Duty

for threaded inserts 22010 & 22012



Threaded Inserts

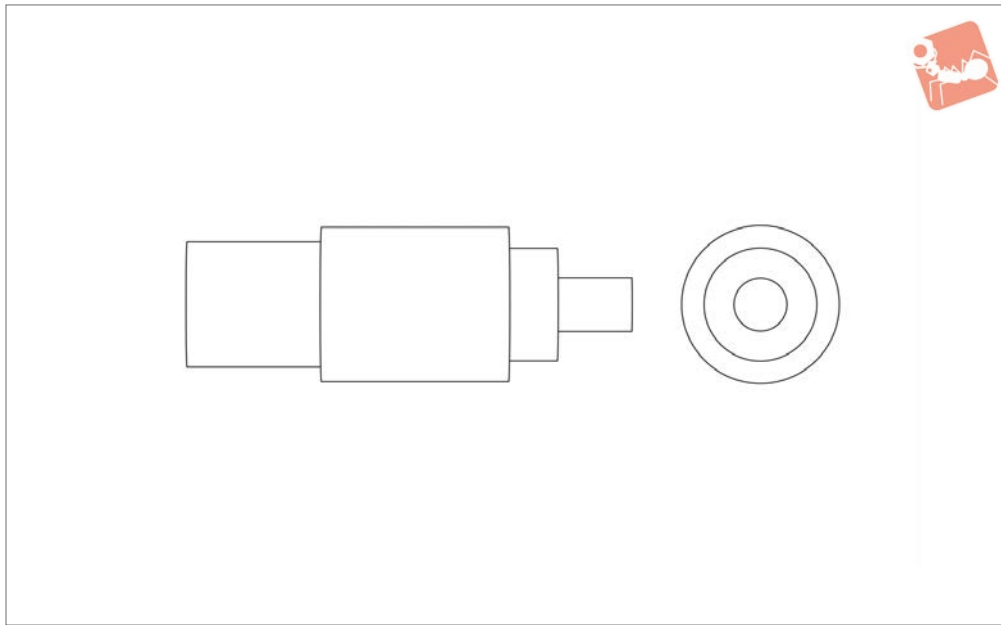

22064

THREADED INSERTS

Material

Steel, blackened.

Tips

For use with inch heavy duty threaded

inserts 22010 and 22012.

Select installation tool of corresponding insert internal thread d_1 and external thread d_2 . If in doubt refer to data tables of

insert where correct „Inst. tool ref.“ is stated.

Order No.	For insert of internal thread = d_1	For insert of external thread = d_2
22064.W0430	M 6x1,00	3/8"-16
22064.W0440	M 8x1,25	1/2"-13
22064.W0450	M10x1,50	5/8"-11
22064.W0470	M12x1,75	3/4"-16
22064.W0480	M14x2,00	7/8"-14
22064.W0490	M16x2,00	1"-12